



**KSYSTEM**  
KÖRNYEZET- ÉS LÉGTECHNIKA

**TRANSLAS**   
DUTCH WELDING TECHNOLOGY

**EXTRACTION**

**NO FUMES, ONLY CLEAN AIR**





## ABOUT TRANSLAS

Translas is a Dutch manufacturer of welding guns since 1960. A company founded by welders, for welders with a passion for innovation and new technologies, continually strives to engineer innovative products that boast a distinctive design, quality, and functionality.

Welder's safety is of paramount importance to Translas. The company's goal is to globally reduce welders' exposure to hazardous fumes and provide a healthier and safer work environment. Some of the pioneering products include extractor guns with a built-in module to safely extract welding fumes at the source and portable extraction units for high-performance extraction.

[www.translas.com](http://www.translas.com)

# TABLE OF CONTENTS

SAFE & EFFECTIVE EXTRACTION OF WELDING FUMES AT THE SOURCE

<b>ABOUT TRANSLAS</b>	<b>2</b>
<b>ABOUT WELDING FUMES</b>	<b>4</b>
<b>8XE MIG EXTRACTOR</b>	<b>5</b>
<b>8XC MIG COBOT EXTRACTOR</b>	<b>23</b>
<b>8TE TIG EXTRACTOR</b>	<b>35</b>
<b>CLEARO2</b>	<b>49</b>



**Extraction Catalogue**

Scan the QR code with your smart phone





## About Welding Fumes:

Welding fumes contain vapours, a mixture of airborne gas by-products and fine particles. The composition of the mixture depends on the welding method and the products that are welded. The vapours and gases released during welding can lead to serious health problems. Short-term exposure can result in nausea, dizziness, or eye, nose, and throat irritation.

Prolonged exposure is like inhaling ultra-fine metal dust which can lead to cancer of the lung, damage to the brain, and kidney damage. Certain gases, such as helium, carbon dioxide, and argon, displace oxygen and argon specifically poses suffocation risks, particularly in enclosed work areas. For this reason, Translas, a Dutch welding torch manufacturer, developed fume welding torches – 8XE MIG, 8XC Cobot, and 8TE TIG Extractors that extract the welding fumes directly at the source up to 98%.

# CLEAN AIR

- ✓ **SOURCE EXTRACTION & FILTRATION**
- ✓ **ENGINEERED FOR THE WELDING PROCESS**
- ✓ **COMPLETE RANGE FOR YOUR PLANT/SHOP**
- ✓ **HIGH QUALITY, TESTED EQUIPMENT**
- ✓ **USER-FRIENDLY UNITS, READY TO USE**

**TRANSLAS**   
DUTCH WELDING TECHNOLOGY

8XE MIG EXTRACTOR

**EXTRACTION**

**NO FUMES, ONLY CLEAN AIR**





# 8XE MIG EXTRACTOR



# CLEAN AIR

## 8XE MIG EXTRACTOR

SAFE & EFFECTIVE EXTRACTION OF WELDING FUMES DIRECTLY AT THE SOURCE.

The 8XE MIG Extractor integrates the most efficient fume extraction structure in the welding industry. The torch comes with three different angles, 30°, 45° and straight. The 8XE MIG Extractor, combined with the ClearO2 W-series 100 and 200, captures up to 98% of welding fumes directly at the source. The 8XE MIG Extractor provides the safest and most effective solution for welders and workers to breathe CLEAN AIR and better work environments.



CLEAN AIR

## SOURCE EXTRACTION



## THE ROBUST CONNECTION BETWEEN SWANNECK & METAL NECK.

The new nozzle holder provides a robust connection between Swanneck and Metal Neck. It is designed to take the biggest blows in any industrial environment.

## UNIQUE NOZZLE DESIGN FOR OPTIMAL PERFORMANCE AND DURABILITY.

The nozzle design is unique to provide the best results. Openings, wall thickness and grip ribs are thoroughly developed for optimal operation and best performance.





# 8XE MIG EXTRACTOR

**MIG**  
EXTRACTOR

## PRODUCT FEATURES

- ✓ RESULTS MEASURED BY DUTCH RESEARCH INSTITUTE (TNO) IN "WORST CASE ROOM"
- ✓ UNIQUE CONTACT TIP FOR MAXIMUM DURABILITY
- ✓ VARIOUS GAS NOZZLES FOR BEST PERFORMANCE
- ✓ DESIGNED FOR ENLARGED ANGULAR MOVEMENT
- ✓ MADE FROM VERY STRONG DSM PLASTIC
- ✓ THE SWAN NECK IS SECURED IN TWO PLACES



- ✓ PATENTED
- ✓ LIGHT-WEIGHT
- ✓ ROBUST

**EXTRACTION**

**Reduces  
Welding Fumes  
up to 98%**

**Lowest  
Under-Pressure  
in the Market**

## ERGONOMIC BALL SOCKET: 30° ANGLE AND 360° ROTATABLE

8XE ball joint has a 30° vertical angular movement combined with a 360° swivel and a full stop. Providing excellent maneuverability and leaving cables and hoses untwisted and thereby leakage and breakage free. This combination is new to the market. It offers excellent maneuverability, maximizing comfort and minimizing fatigue.





# 8XE MINI MIG EXTRACTOR LINE

**MIG**  
EXTRACTOR

CLEAN AIR



**8XE MIG EXTRACTOR**

**200** AIR COOLED  
**MINI**

CO2 - 230 AMP  
Mixed Gases - 200 AMP  
Duty Cycle - 100%  
Weight\*: 1.09KG



**8XE MIG EXTRACTOR**

**250** AIR COOLED  
**MINI**

CO2 - 280 AMP  
Mixed Gases - 250 AMP  
Duty Cycle - 100%  
Weight\*: 1.34KG



**8XE MIG EXTRACTOR**

**320** WATER COOLED  
**MINI**

CO2 - 360 AMP  
Mixed Gases - 320 AMP  
Duty Cycle - 100%  
Weight\*: 1.47KG

\* The torch's weight is measured by a distance of one meter from the ground.





# 8XE MIG REGULAR EXTRACTOR LINE

**MIG**  
EXTRACTOR



**8XE MIG EXTRACTOR**

**300 AIR COOLED**

CO2 - 320 AMP  
Mixed Gases - 300 AMP  
Duty Cycle - 100%  
Weight\*: 1.59KG



**8XE MIG EXTRACTOR**

**500 WATER COOLED**

CO2 - 550 AMP  
Mixed Gases - 500 AMP  
Duty Cycle - 100%  
Weight\*: 1.68KG

**EXTRACTION**

\* The torch's weight is measured by a distance of one meter from the ground.



# 8XE MINI 200 MIG EXTRACTOR

CO2 - 230 AMP, MIXED GASES - 200 AMP, DUTY CYCLE - 100%

# MIG EXTRACTOR

AIR COOLED

CLEAN AIR

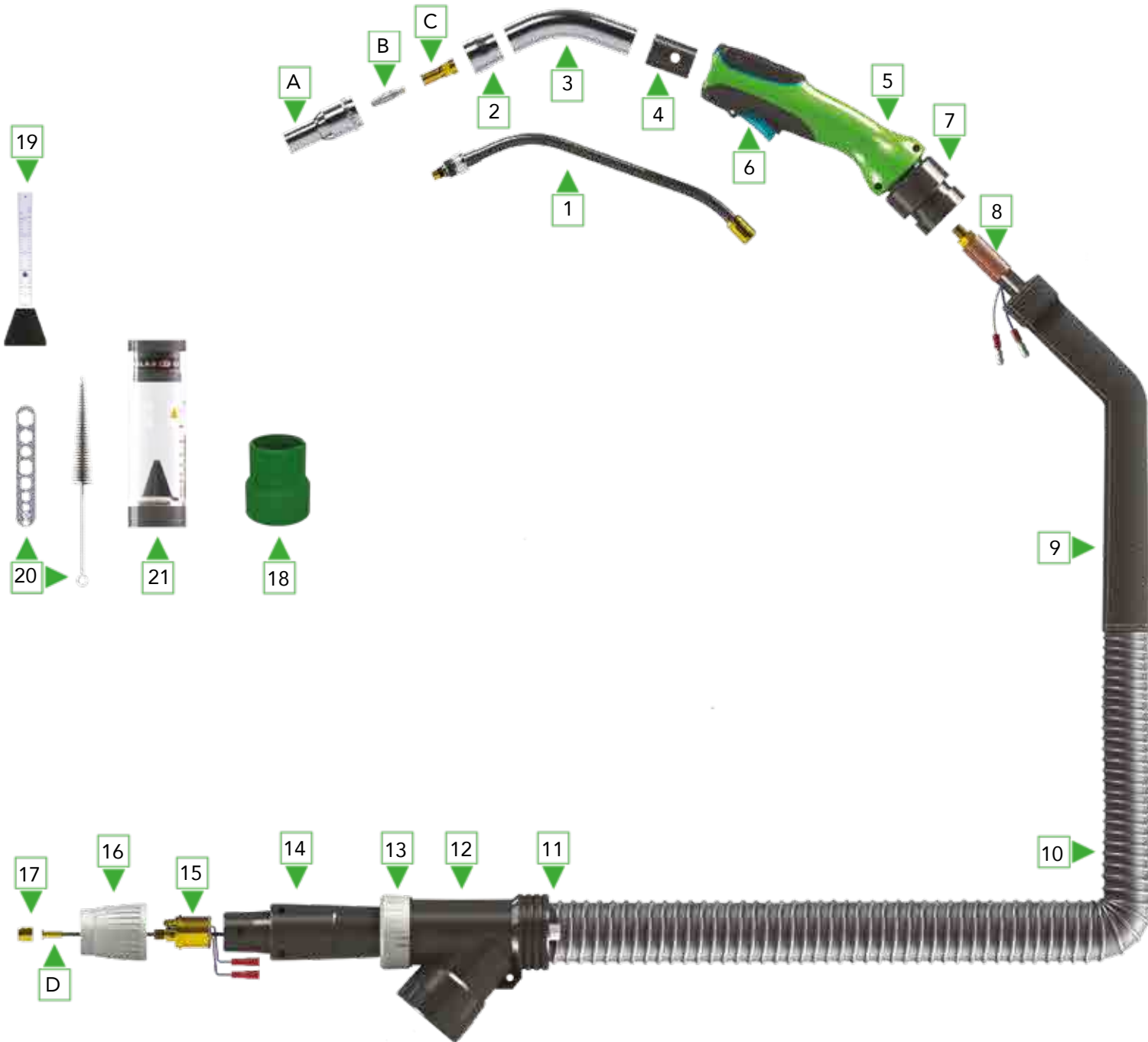

PART NO.	DESCRIPTION	PACK QTY
<b>COMPLETE TORCHES</b>		
8XE1001301000	8XE MINI 200 Extractor 3mtr gas cooled - 45° (standard)	1
8XE1001401000	8XE MINI 200 Extractor 4mtr gas cooled - 45° (standard)	1
8XE1001501000	8XE MINI 200 Extractor 5mtr gas cooled - 45° (standard)	1
8XE1101301000	8XE MINI 200 Extractor 3mtr gas cooled - 30°	1
8XE1101401000	8XE MINI 200 Extractor 4mtr gas cooled - 30°	1
8XE1101501000	8XE MINI 200 Extractor 5mtr gas cooled - 30°	1

ITEM	PART NO.	DESCRIPTION	PACK QTY
<b>CONSUMABLES</b>			
A	3937000	Nozzle conical 12mm	5
	3937001	Nozzle conical 14mm special	5
	3937002	Nozzle conical 14mm	5
B	399080	Contact tip 8XC/8XE - 0,8	25
	399010	Contact tip 8XC/8XE - 1,0	25
	399012	Contact tip 8XC/8XE - 1,2	25
	3990102	Contact tip 8XC/8XE - 1,0 Alu	25
	3990122	Contact tip 8XC/8XE - 1,2 Alu	25
	3990101	Contact tip 8XC/8XE - 1,0 CuCrZr	25
	3990121	Contact tip 8XC/8XE - 1,2 CuCrZr	25
C	39327110	Tip adapter	10
D	301535	Plastic coated liner blue (1,5/4,5) 3mtr - for 0,8mm steel wire	1
	301545	Plastic coated liner blue (1,5/4,5) 4mtr - for 0,8mm steel wire	1
	301555	Plastic coated liner blue (1,5/4,5) 5mtr - for 0,8mm steel wire	1
	302535	Plastic coated liner red (2,0/4,5) 3mtr - for 1,0/1,2mm steel wire	1
	302545	Plastic coated liner red (2,0/4,5) 4mtr - for 1,0/1,2mm steel wire	1
	302555	Plastic coated liner red (2,0/4,5) 5mtr - for 1,0/1,2mm steel wire	1
	301538	Teflon liner blue (1.5/4.0) 3mtr - for 0,8mm aluminium wire	1
	301548	Teflon liner blue (1.5/4.0) 4mtr - for 0,8mm aluminium wire	1
	301558	Teflon liner blue (1.5/4.0) 5mtr - for 0,8mm aluminium wire	1
	302538	Teflon liner red (2.0/4.0) 3mtr - for 1,0-1,2mm aluminium wire	1
	302548	Teflon liner red (2.0/4.0) 4mtr - for 1,0-1,2mm aluminium wire	1
	302558	Teflon liner red (2.0/4.0) 5mtr - for 1,0-1,2mm aluminium wire	1



ITEM	PART NO.	DESCRIPTION	PACK QTY
<b>SPARE PARTS</b>			
1	39301045	Swanneck 45°	1
	39301030	Swanneck 30°	1
	3950005	PEEK ring to fix nozzle holder (not shown)	5
2	3950000	Nozzle holder	1
3	3950045	Metal neck 45°	1
	3950046	Metal neck 30°	1
4	3950500	Adapter to fit MINI neck	1
5	391000	Handle green/black complete with trigger	1
6	3912009	Trigger with spring	1
	391250	Micro switch complete (not shown)	1
7	381900	Cable support set with ball-and-socket joint	1
8	259163X8	Cable assembly 3mtr	1
	259164X8	Cable assembly 4mtr	1
	259165X8	Cable assembly 5mtr	1
9	260019	Leather-sheathing with Velcro 2mtr	1
10	340303	Fume extraction hose 30-38mm 3mtr	1
	340304	Fume extraction hose 30-38mm 4mtr	1
	340305	Fume extraction hose 30-38mm 5mtr	1
11	398031	Hose connection	1
12	398100	Housing (Y-shape) for fume extraction hose	1
13	398015	Connection ring	1
14	398010	Housing set for central connector	1
15	305298E23	Central connector Euro	1
16	8M9420	Adaptor nut	2
17	305315	Liner positioner nut	10
18	398110	Hose adapter	1
19	406050	Gasflow meter	1
20	371208	Tool set (brush and multitool)	1
21	371350	Airflow meter MINI Extractor	1
-	320300	Ceramic dry film spray 400 ml (not shown)	12

## 8XE MINI 250 MIG EXTRACTOR

CO2 - 280 AMP, MIXED GASES - 250 AMP, DUTY CYCLE - 100%



AIR COOLED

CLEAN AIR

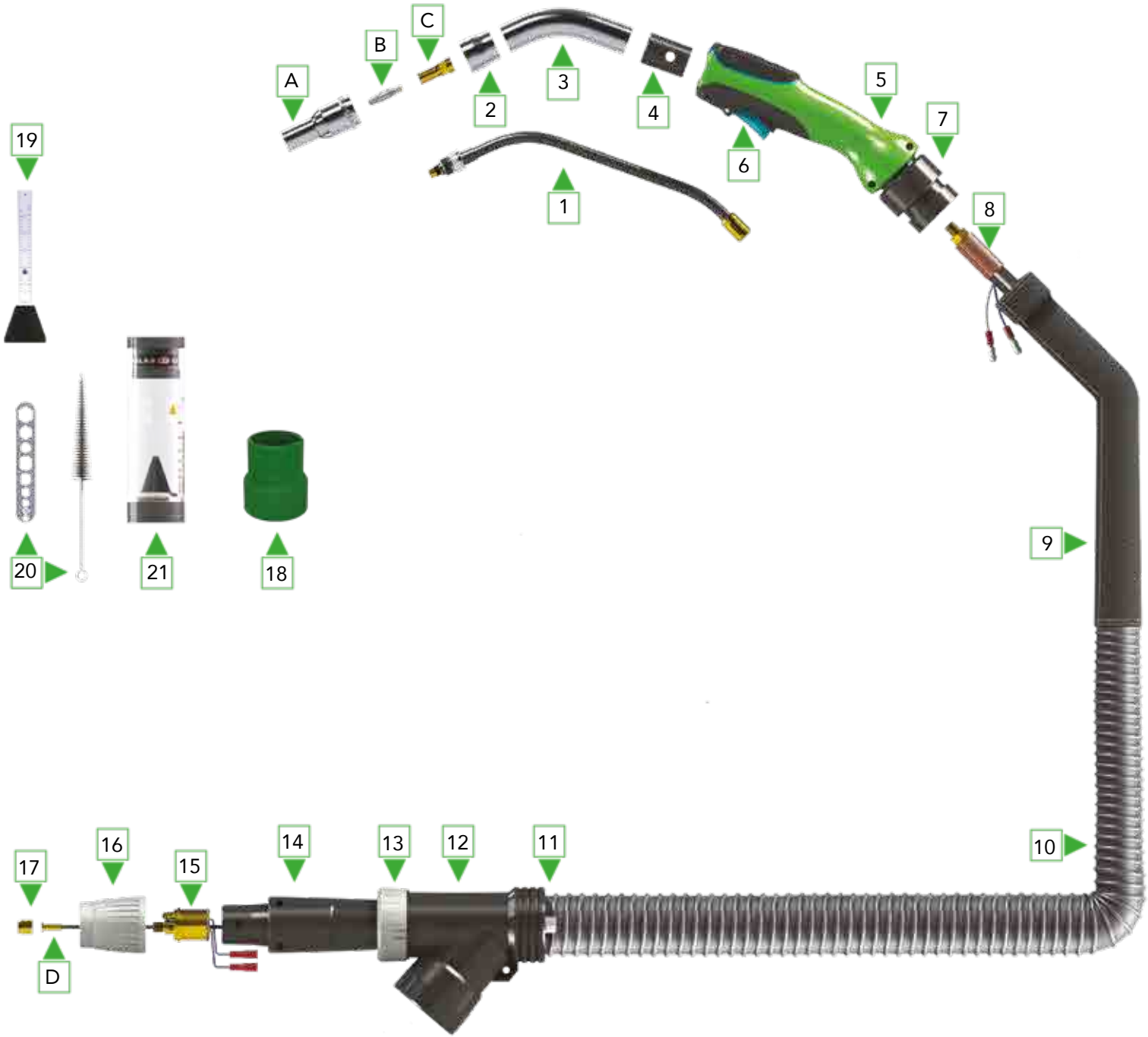

PART NO.	DESCRIPTION	PACK QTY
<b>COMPLETE TORCHES</b>		
8XE1000301000	8XE MINI 250 Extractor 3mtr gas cooled - 45° (standard)	1
8XE1000401000	8XE MINI 250 Extractor 4mtr gas cooled - 45° (standard)	1
8XE1000501000	8XE MINI 250 Extractor 5mtr gas cooled - 45° (standard)	1
8XE1100301000	8XE MINI 250 Extractor 3mtr gas cooled - 30°	1
8XE1100401000	8XE MINI 250 Extractor 4mtr gas cooled - 30°	1
8XE1100501000	8XE MINI 250 Extractor 5mtr gas cooled - 30°	1

ITEM	PART NO.	DESCRIPTION	PACK QTY
<b>CONSUMABLES</b>			
A	3937000	Nozzle conical 12mm	5
	3937001	Nozzle conical 14mm special	5
	3937002	Nozzle conical 14mm	5
B	399080	Contact tip 8XC/8XE - 0,8	25
	399010	Contact tip 8XC/8XE - 1,0	25
	399012	Contact tip 8XC/8XE - 1,2	25
	3990102	Contact tip 8XC/8XE - 1,0 Alu	25
	3990122	Contact tip 8XC/8XE - 1,2 Alu	25
	3990101	Contact tip 8XC/8XE - 1,0 CuCrZr	25
	3990121	Contact tip 8XC/8XE - 1,2 CuCrZr	25
C	39327110	Tip adapter	10
D	301535	Plastic coated liner blue (1,5/4,5) 3mtr - for 0,8mm steel wire	1
	301545	Plastic coated liner blue (1,5/4,5) 4mtr - for 0,8mm steel wire	1
	301555	Plastic coated liner blue (1,5/4,5) 5mtr - for 0,8mm steel wire	1
	302535	Plastic coated liner red (2,0/4,5) 3mtr - for 1,0/1,2mm steel wire	1
	302545	Plastic coated liner red (2,0/4,5) 4mtr - for 1,0/1,2mm steel wire	1
	302555	Plastic coated liner red (2,0/4,5) 5mtr - for 1,0/1,2mm steel wire	1
	301538	Teflon liner blue (1.5/4.0) 3mtr - for 0,8mm aluminium wire	1
	301548	Teflon liner blue (1.5/4.0) 4mtr - for 0,8mm aluminium wire	1
	301558	Teflon liner blue (1.5/4.0) 5mtr - for 0,8mm aluminium wire	1
	302538	Teflon liner red (2.0/4.0) 3mtr - for 1,0-1,2mm aluminium wire	1
	302548	Teflon liner red (2.0/4.0) 4mtr - for 1,0-1,2mm aluminium wire	1
	302558	Teflon liner red (2.0/4.0) 5mtr - for 1,0-1,2mm aluminium wire	1



ITEM	PART NO.	DESCRIPTION	PACK QTY
<b>SPARE PARTS</b>			
1	39301045	Swanneck 45°	1
	39301030	Swanneck 30°	1
	3950005	PEEK ring to fix nozzle holder (not shown)	5
2	3950000	Nozzle holder	1
3	3950045	Metal neck 45°	1
	3950046	Metal neck 30°	1
4	3950500	Adapter to fit MINI neck	1
5	391000	Handle green/black complete with trigger	1
6	3912009	Trigger with spring	1
	391250	Micro switch complete (not shown)	1
7	381900	Cable support set with ball-and-socket joint	1
8	259263X8	Cable assembly 3mtr	1
	259264X8	Cable assembly 4mtr	1
	259265X8	Cable assembly 5mtr	1
9	260019	Leather-sheathing with Velcro 2mtr	1
10	340303	Fume extraction hose 30-38mm 3mtr	1
	340304	Fume extraction hose 30-38mm 4mtr	1
	340305	Fume extraction hose 30-38mm 5mtr	1
11	398031	Hose connection	1
12	398100	Housing (Y-shape) for fume extraction hose	1
13	398015	Connection ring	1
14	398010	Housing set for central connector	1
15	305298E23	Central connector Euro	1
16	8M9420	Adaptor nut	2
17	305315	Liner positioner nut	10
18	398110	Hose adapter	1
19	406050	Gasflow meter	1
20	371208	Tool set (brush and multitool)	1
21	371350	Airflow meter MINI Extractor	1
-	320300	Ceramic dry film spray 400 ml (not shown)	12

## 8XE MINI 320 MIG EXTRACTOR

CO2 - 360 AMP, MIXED GASES - 320 AMP, DUTY CYCLE - 100%



WATER COOLED

CLEAN AIR

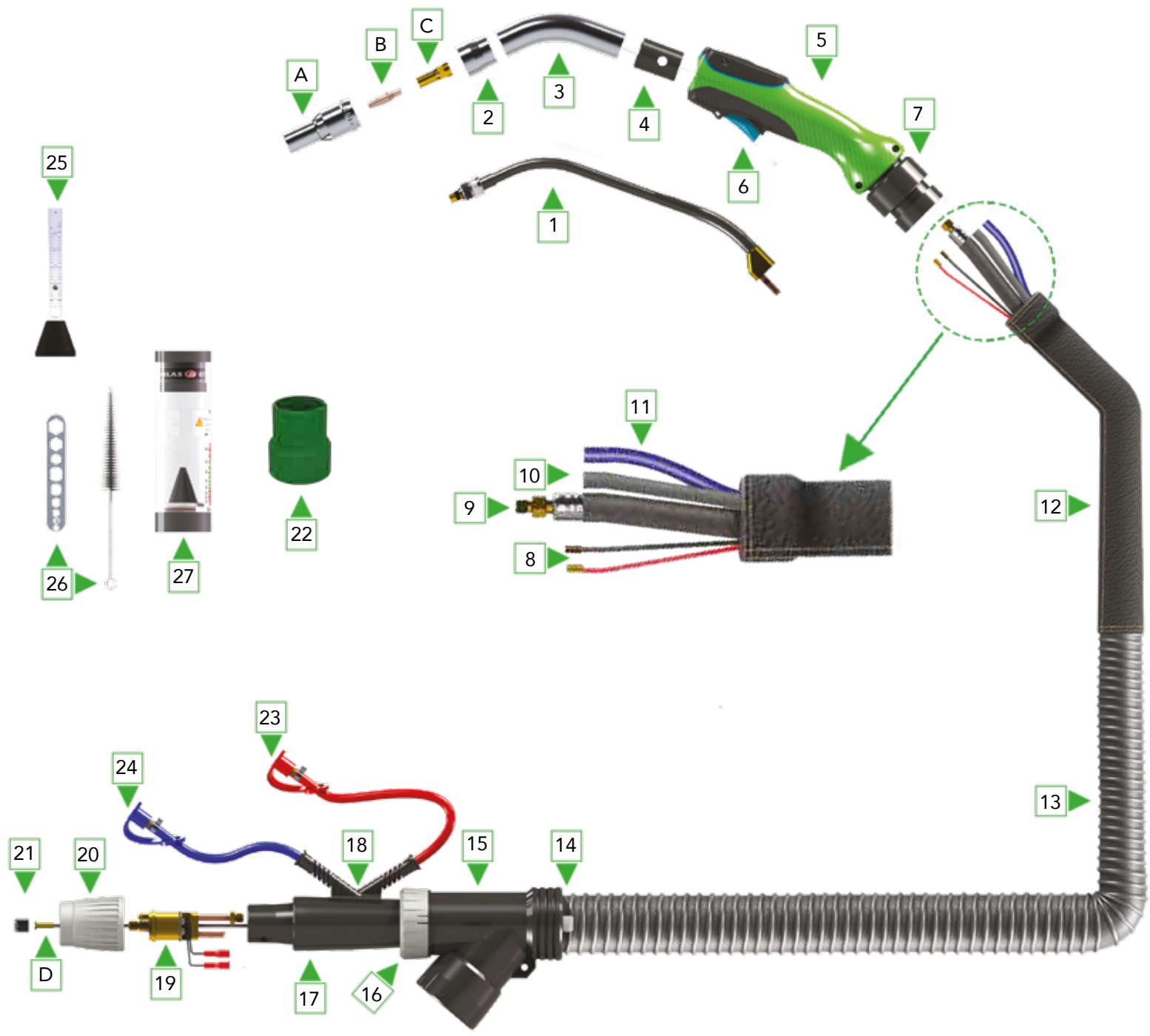

PART NO.	DESCRIPTION	PACK	QTY
<b>COMPLETE TORCHES</b>			
8XE2060301000	8XE MINI Extractor 320 3mtr water cooled - 45° (standard)	1	
8XE2060401000	8XE MINI Extractor 320 4mtr water cooled - 45° (standard)	1	
8XE2060501000	8XE MINI Extractor 320 5mtr water cooled - 45° (standard)	1	

ITEM	PART NO.	DESCRIPTION	PACK	QTY
<b>CONSUMABLES</b>				
A	3937000	Nozzle conical 12mm	5	
	3937001	Nozzle conical 14mm special	5	
	3937002	Nozzle conical 14mm	5	
B	399080	Contact tip 8XC/8XE - 0,8	25	
	399010	Contact tip 8XC/8XE - 1,0	25	
	399012	Contact tip 8XC/8XE - 1,2	25	
	3990102	Contact tip 8XC/8XE - 1,0 Alu	25	
	3990122	Contact tip 8XC/8XE - 1,2 Alu	25	
	3990101	Contact tip 8XC/8XE - 1,0 CuCrZr	25	
	3990121	Contact tip 8XC/8XE - 1,2 CuCrZr	25	
C	39327110	Tip adapter	10	
D	301535	Plastic coated liner blue (1,5/4,5) 3mtr - for 0,8mm steel wire	1	
	301545	Plastic coated liner blue (1,5/4,5) 4mtr - for 0,8mm steel wire	1	
	301555	Plastic coated liner blue (1,5/4,5) 5mtr - for 0,8mm steel wire	1	
	302535	Plastic coated liner red (2,0/4,5) 3mtr - for 1,0/1,2mm steel wire	1	
	302545	Plastic coated liner red (2,0/4,5) 4mtr - for 1,0/1,2mm steel wire	1	
	302555	Plastic coated liner red (2,0/4,5) 5mtr - for 1,0/1,2mm steel wire	1	
	301538	Teflon liner blue (1.5/4.0) 3mtr - for 0,8mm aluminium wire	1	
	301548	Teflon liner blue (1.5/4.0) 4mtr - for 0,8mm aluminium wire	1	
	301558	Teflon liner blue (1.5/4.0) 5mtr - for 0,8mm aluminium wire	1	
	302538	Teflon liner red (2.0/4.0) 3mtr - for 1,0-1,2mm aluminium wire	1	
	302548	Teflon liner red (2.0/4.0) 4mtr - for 1,0-1,2mm aluminium wire	1	
	302558	Teflon liner red (2.0/4.0) 5mtr - for 1,0-1,2mm aluminium wire	1	



ITEM	PART NO.	DESCRIPTION	PACK	QTY
<b>SPARE PARTS</b>				
1	39304045	Swanneck 45°	1	
	3950005	PEEK ring to fix nozzle holder (not shown)	5	
2	3950000	Nozzle holder	1	
3	3950045	Metal neck 45°	1	
4	3950500	Adapter to fit MINI neck	1	
5	391000	Handle green/black complete with trigger	1	
6	3912009	Trigger with spring	1	
	391250	Micro switch complete (not shown)	1	
7	381920	Cable support set with ball-and-socket join	1	
8	306505	Switch cable 1x0,75mm² per mtr	100	
9	258513X8	Power/water cable 3mtr	1	
	258514X8	Power/water cable 4mtr	1	
	258515X8	Power/water cable 5mtr	1	
10	2585313XE	Outer liner 3mtr	1	
	2585314XE	Outer liner 4mtr	1	
	2585315XE	Outer liner 5mtr	1	
11	258535	Water inlet hose 5x8mm blue per mtr	100	
	258566	Water outlet hose 5x8mm red per mtr	100	
12	260018	Leather-sheathing with Velcro 2mtr	1	
13	3402032	Fume extraction hose 36-44mm 3mtr	1	
	3402042	Fume extraction hose 36-44mm 4mtr	1	
	3402052	Fume extraction hose 36-44mm 5mtr	1	
14	398030	Hose connection	1	
15	398100	Housing (Y-shape) for fume extraction hose	1	
16	398015	Connection ring	1	
17	398010	Housing set for central connector	1	
18	350881	Water hose guide	1	
19	305304E23	Central connector Euro	1	
20	8M9420	Adaptor nut	2	
21	305315	Liner positioner nut	10	
22	398110	Hose adapter	1	
23	258701	Waterstop red	10	
24	258702	Waterstop bluer	10	
25	406050	Gasflow meter	1	
26	371208	Tool set (brush and multitool)	1	
27	371350	Airflow meter Extractor	1	
-	320300	Ceramic dry film spray 400 ml (not shown)	12	

## 8XE MIG 300 EXTRACTOR

CO2 - 320 AMP, MIXED GASES - 300 AMP, DUTY CYCLE - 100%



AIR COOLED

CLEAN AIR

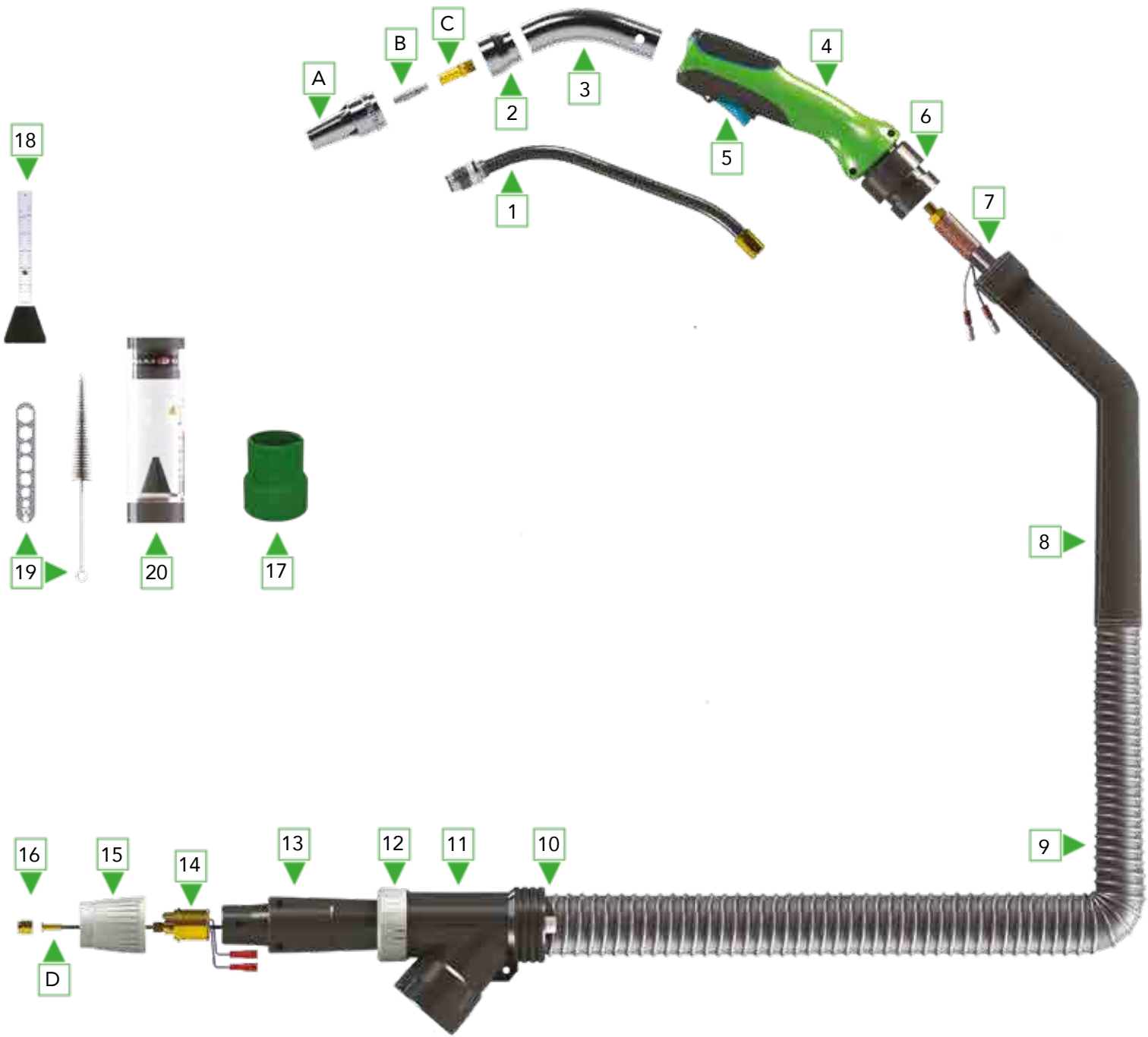



PART NO.	DESCRIPTION	PACK	QTY
<b>COMPLETE TORCHES</b>			
8XE3020301000	8XE Extractor 300 3mtr gas cooled - 45° (standard)	1	
8XE3020401000	8XE Extractor 300 4mtr gas cooled - 45° (standard)	1	
8XE3020501000	8XE Extractor 300 5mtr gas cooled - 45° (standard)	1	
8XE3120301000	8XE Extractor 300 3mtr gas cooled - 30°	1	
8XE3120401000	8XE Extractor 300 4mtr gas cooled - 30°	1	
8XE3120501000	8XE Extractor 300 5mtr gas cooled - 30°	1	

ITEM	PART NO.	DESCRIPTION	PACK	QTY
<b>CONSUMABLES</b>				
A	3937041	Nozzle 8XC/8XE Extractor 14mm special	5	
	3937045	Nozzle 8XC/8XE Extractor 17mm special	5	
B	399010	Contact tip 8XC/8XE - 1,0	25	
	399012	Contact tip 8XC/8XE - 1,2	25	
	399016	Contact tip 8XC/8XE - 1,6	25	
	3990102	Contact tip 8XC/8XE - 1,0 Alu	25	
	3990122	Contact tip 8XC/8XE - 1,2 Alu	25	
	3990101	Contact tip 8XC/8XE - 1,0 CuCrZr	25	
	3990121	Contact tip 8XC/8XE - 1,2 CuCrZr	25	
	3990161	Contact tip 8XC/8XE - 1,6 CuCrZr	25	
C	39327210	Tip adapter	10	
D	302535	Plastic coated liner red (2,0/4,5) 3mtr -for 1,0/1,2mm wire	1	
	302545	Plastic coated liner red (2,0/4,5) 4mtr -for 1,0/1,2mm wire	1	
	302555	Plastic coated liner red (2,0/4,5) 5mtr -for 1,0/1,2mm wire	1	
	303635	Plastic coated liner yellow (2,5/4,5) 3mtr -for 1,6mm wire	1	
	303645	Plastic coated liner yellow (2,5/4,5) 4mtr -for 1,6mm wire	1	
	303655	Plastic coated liner yellow (2,5/4,5) 5mtr -for 1,6mm wire	1	
	302538	Teflon red (2.0/4.0) 3mtr - for 1,0-1,2mm aluminium wire	1	
	302548	Teflon red (2.0/4.0) 4mtr - for 1,0-1,2mm aluminium wire	1	
	302558	Teflon red (2.0/4.0) 5mtr - for 1,0-1,2mm aluminium wire	1	
	303638	Teflon yellow (2.7/4.7) 3mtr - for 1,6mm aluminium wire	1	
	303648	Teflon yellow (2.7/4.7) 4mtr - for 1,6mm aluminium wire	1	
	303658	Teflon yellow (2.7/4.7) 5mtr - for 1,6mm aluminium wire	1	
	304830	Graphite liner black (2,0/4,0) 3mtr combiliner- for 1,0/1,2mm wire	1	
	304831	Graphite liner black (2,0/4,0) 4mtr combiliner- for 1,0/1,2mm wire	1	
	304832	Graphite liner black (2,0/4,0) 5mtr combiliner- for 1,0/1,2mm wire	1	
	3048351	Graphite liner black (2,3/4,7) 3mtr combiliner- for 1,6mm wire	1	
	3048361	Graphite liner black (2,3/4,7) 4mtr combiliner- for 1,6mm wire	1	
	3048371	Graphite liner black (2,3/4,7) 5mtr combiliner- for 1,6mm wire	1	



ITEM	PART NO.	DESCRIPTION	PACK	QTY
<b>SPARE PARTS</b>				
1	39302045	Swanneck 45°	1	
	39302030	Swanneck 30°	1	
	3950205	PEEK ring to fix nozzle holder (not shown)	5	
2	3950200	Nozzle holder	1	
3	3950245	Metal neck 45°	1	
	3950246	Metal neck 30°	1	
4	391000	Handle green/black complete with trigger	1	
5	3912009	Trigger with spring	1	
	391250	Micro switch complete (not shown)	1	
6	381920	Cable support set with ball-and-socket joint	1	
7	259363X8	Cable assembly 3mtr	1	
	259364X8	Cable assembly 4mtr	1	
	259365X8	Cable assembly 5mtr	1	
8	260018	Leather-sheathing with Velcro 2mtr	1	
9	3402032	Fume extraction hose 36-44mm 3mtr	1	
	3402042	Fume extraction hose 36-44mm 4mtr	1	
	3402052	Fume extraction hose 36-44mm 5mtr	1	
10	398030	Hose connection	1	
11	398100	Housing (Y-shape) for fume extraction hose	1	
12	398015	Connection ring	1	
13	398010	Housing set for central connector	1	
14	305298E23	Central connector Euro	1	
15	8M9420	Adaptor nut	2	
16	305315	Liner positioner nut	10	
17	398110	Hose adapter	1	
18	406050	Gasflow meter	1	
19	371208	Tool set (brush and multitool)	1	
20	371300	Airflow meter Extractor	1	
-	320300	Ceramic dry film spray 400 ml (not shown)	12	

## 8XE MIG 500 EXTRACTOR

CO2 - 550 AMP, MIXED GASES - 500 AMP, DUTY CYCLE - 100%



WATER COOLED

CLEAN AIR

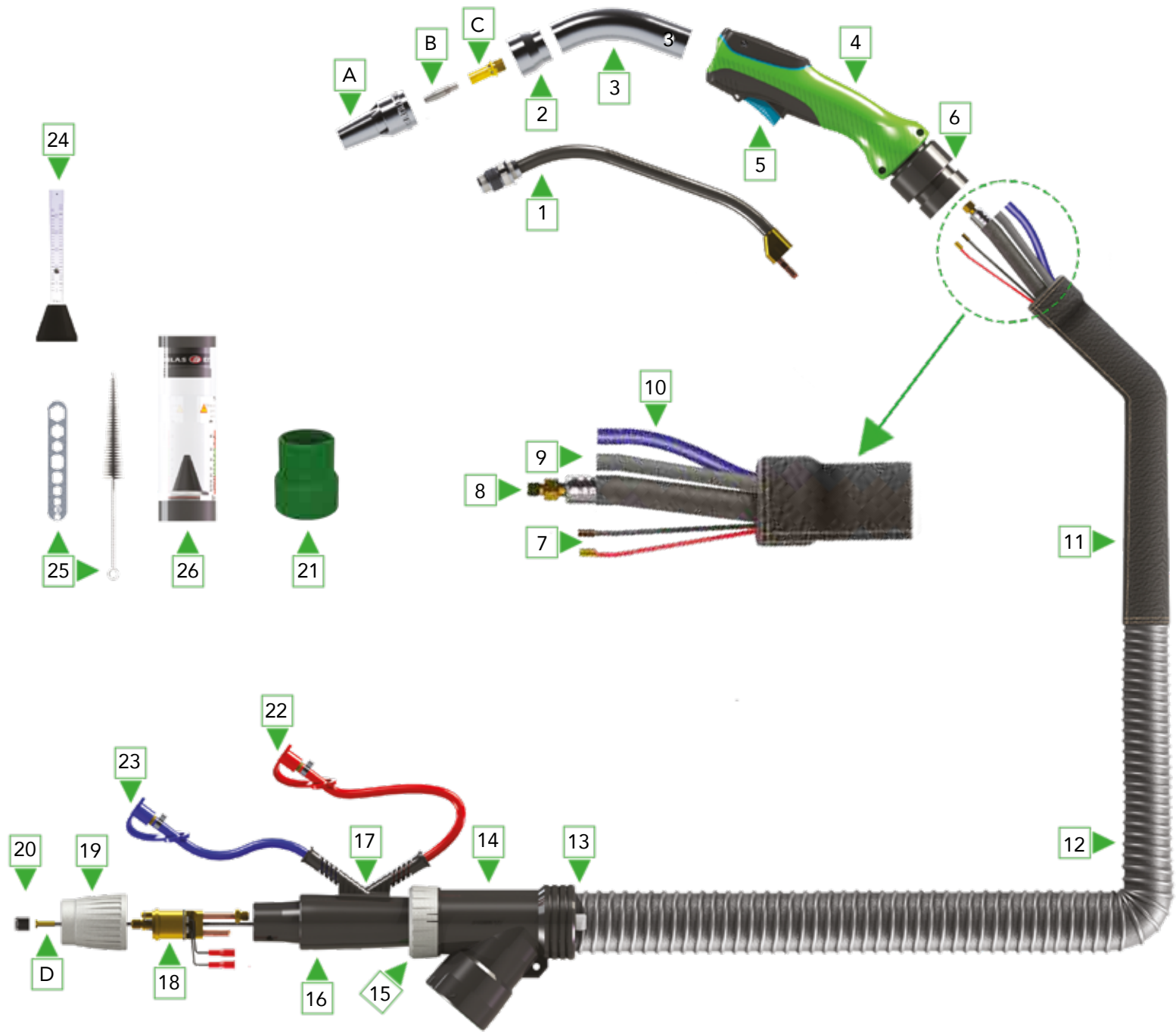

PART NO.	DESCRIPTION	PACK	QTY
<b>COMPLETE TORCHES</b>			
8XE5060301000	8XE Extractor 500 3mtr water cooled - 45° (standard)	1	
8XE5060401000	8XE Extractor 500 4mtr water cooled - 45° (standard)	1	
8XE5060501000	8XE Extractor 500 5mtr water cooled - 45° (standard)	1	
8XE5160301000	8XE Extractor 500 3mtr water cooled - 30°	1	
8XE5160401000	8XE Extractor 500 4mtr water cooled - 30°	1	
8XE5160501000	8XE Extractor 500 5mtr water cooled - 30°	1	

ITEM	PART NO.	DESCRIPTION	PACK	QTY
<b>CONSUMABLES</b>				
A	3937041	Nozzle 8XC/8XE Extractor 14mm special	5	
	3937045	Nozzle 8XC/8XE Extractor 17mm special	5	
B	399010	Contact tip 8XC/8XE - 1,0	25	
	399012	Contact tip 8XC/8XE - 1,2	25	
	399016	Contact tip 8XC/8XE - 1,6	25	
	3990102	Contact tip 8XC/8XE - 1,0 Alu	25	
	3990122	Contact tip 8XC/8XE - 1,2 Alu	25	
	3990101	Contact tip 8XC/8XE - 1,0 CuCrZr	25	
	3990121	Contact tip 8XC/8XE - 1,2 CuCrZr	25	
	3990161	Contact tip 8XC/8XE - 1,6 CuCrZr	25	
C	39327210	Tip adapter	10	
D	302535	Plastic coated liner red (2,0/4,5) 3mtr -for 1,0/1,2mm wire	1	
	302545	Plastic coated liner red (2,0/4,5) 4mtr -for 1,0/1,2mm wire	1	
	302555	Plastic coated liner red (2,0/4,5) 5mtr -for 1,0/1,2mm wire	1	
	303635	Plastic coated liner yellow (2,5/4,5) 3mtr -for 1,6mm wire	1	
	303645	Plastic coated liner yellow (2,5/4,5) 4mtr -for 1,6mm wire	1	
	303655	Plastic coated liner yellow (2,5/4,5) 5mtr -for 1,6mm wire	1	
	302538	Teflon red (2.0/4.0) 3mtr - for 1,0-1,2mm aluminium wire	1	
	302548	Teflon red (2.0/4.0) 4mtr - for 1,0-1,2mm aluminium wire	1	
	302558	Teflon red (2.0/4.0) 5mtr - for 1,0-1,2mm aluminium wire	1	
	303638	Teflon yellow (2.7/4.7) 3mtr - for 1,6mm aluminium wire	1	
	303648	Teflon yellow (2.7/4.7) 4mtr - for 1,6mm aluminium wire	1	
	303658	Teflon yellow (2.7/4.7) 5mtr - for 1,6mm aluminium wire	1	
	304830	Graphite liner black (2,0/4,0) 3mtr combiliner- for 1,0/1,2mm wire	1	
	304831	Graphite liner black (2,0/4,0) 4mtr combiliner- for 1,0/1,2mm wire	1	
	304832	Graphite liner black (2,0/4,0) 5mtr combiliner- for 1,0/1,2mm wire	1	
	3048351	Graphite liner black (2,3/4,7) 3mtr combiliner- for 1,6mm wire	1	
	3048361	Graphite liner black (2,3/4,7) 4mtr combiliner- for 1,6mm wire	1	
	3048371	Graphite liner black (2,3/4,7) 5mtr combiliner- for 1,6mm wire	1	



ITEM	PART NO.	DESCRIPTION	PACK	QTY
<b>SPARE PARTS</b>				
1	39303045	Swanneck 45°	1	
	39303030	Swanneck 30°	1	
	3950205	PEEK ring to fix nozzle holder (not shown)	5	
2	3950200	Nozzle holder	1	
3	3950245	Metal neck 45°	1	
	3950246	Metal neck 30°	1	
4	391000	Handle green/black complete with trigger	1	
5	3912009	Trigger with spring	1	
	391250	Micro switch complete (not shown)	1	
6	381920	Cable support set with ball-and-socket join	1	
7	306505	Switch cable 1x0,75mm <sup>2</sup> per mtr	100	
8	258513X8	Power/water cable 3mtr	1	
	258514X8	Power/water cable 4mtr	1	
	258515X8	Power/water cable 5mtr	1	
9	2585313XE	Outer liner 3mtr	1	
	2585314XE	Outer liner 4mtr	1	
	2585315XE	Outer liner 5mtr	1	
10	258535	Water inlet hose 5x8mm blue per mtr	100	
	258566	Water outlet hose 5x8mm red per mtr	100	
11	260018	Leather-sheathing with Velcro 2mtr	1	
12	3402032	Fume extraction hose 36-44mm 3mtr	1	
	3402042	Fume extraction hose 36-44mm 4mtr	1	
	3402052	Fume extraction hose 36-44mm 5mtr	1	
13	398030	Hose connection	1	
14	398100	Housing (Y-shape) for fume extraction hose	1	
15	398015	Connection ring	1	
16	398010	Housing set for central connector	1	
17	350881	Water hose guide	1	
18	305304E23	Central connector Euro	1	
19	8M9420	Adaptor nut	2	
20	305315	Liner positioner nut	10	
21	398110	Hose adapter	1	
22	258701	Waterstop red	10	
23	258702	Waterstop bluer	10	
24	406050	Gasflow meter	1	
25	371208	Tool set (brush and multitool)	1	
26	371300	Airflow meter Extractor	1	
-	320300	Ceramic dry film spray 400 ml (not shown)	12	



# 8XE MIG EXTRACTOR

CONSUMABLES TO FIT YOUR SPECIFIC WELDING APPLICATION



The purpose of the bottom caps on 8XE MIG Extractor is to provide a solid welding platform. The bottom caps are available for 8XE MIG Extractor 30°, 45°, and straight version

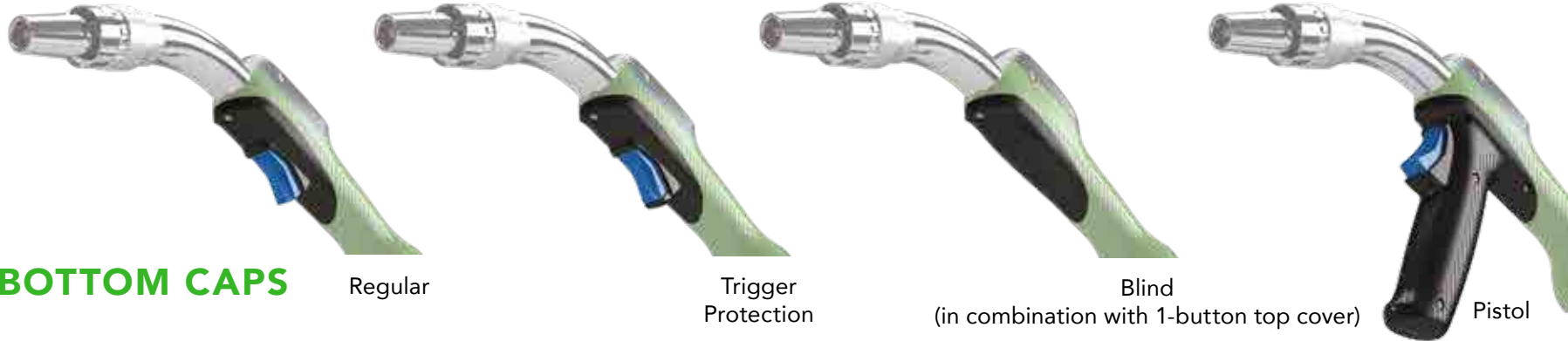

## BOTTOM CAPS

Regular

Trigger Protection

Blind  
(in combination with 1-button top cover)

Pistol

## CONTACT TIPS



The specially designed nickel-plated contact tips for the complete 8XE MIG & 8XC Cobot Extractor series are designed for a longer lifetime.

### You can choose from:

- Standard copper for everyday welding.
- Available in sizes from .030"(0.8mm) - .095" (2.4mm.)
- Special tips for aluminum welding.

## NOZZLE OPTIONS

There are different nozzle variations to suit any kind of joint application and deliver best welding results. The nozzles can be changed in a second.

### MINI EXTRACTOR

12mm

The nozzle offers slightly more comprehensive shielding gas coverage on medium-thickness materials in butt and fillet applications, and outside-corner joints.



12MM

### 8XE REGULAR / MINI

14mm-Special

Where space is limited and fit is tight, this nozzle offers better access and more excellent shielding gas coverage to prevent porosity. This 14mm special nozzle is delivered as a standard on every extractor torch.



SPECIAL  
14MM

### 8XE REGULAR

17mm-Special

For heavier-thickness, high-current and high-deposition butt and lap joint applications, this nozzle offers more excellent shielding gas coverage to prevent porosity.



SPECIAL  
17MM

CLEAN AIR



# 8XE MIG EXTRACTOR

CONSUMABLES TO FIT YOUR SPECIFIC WELDING APPLICATION

# MIG EXTRACTOR

## TOP COVER MODULES



Standard

Pressure Relief

One Button

Up / Down

Potential Meter (Special request depending on welding machine)

## LINERS

Choose the right liner for your wire diameter and type when working with a 8XE Extractor Torch:

 **Blue:** (1.5/4.5) from 3mtr to 5mtr

 **Red:** (2.0/4.5) from 3mtr to 5mtr

 **Yellow:** (2.5/4.5) from 3mtr to 5mtr

All liner types are suitable for stainless steel applications. For Aluminium application, there are the following types:

**Blue , Red and Yellow in Teflon.**



## WIRE FEED CONNECTORS

### EURO CONNECTOR

There are wire feed connectors available to fit any type of machine. Due to the design of the backend housing, you can switch between the connector types with ease.



## MAINTENANCE

### AIRFLOW METER

Always use the Airflow meter to ensure maximum extraction effect.

### GAS METER

The gas meter is used for best weld quality by keeping the right amount of shielding gas around the weld seam.

### CERAMIC SPRAY

Prolong the life of your gun and all spare parts by applying the ceramic spray to the 8XE Extractor before work.



EXTRACTION



PARTNR: 399 1022

**TRANSLAS** <sup>®</sup>  
DUTCH WELDING TECHNOLOGY

# 8XC COBOT MIG EXTRACTOR





# 8XC COBOT MIG EXTRACTOR

## SOURCE EXTRACTION

**COBOT  
EXTRACTOR**

# 8XC COBOT

**MADE FOR COBOT AND SEMI-AUTOMATIC SOLUTIONS**

**Certified By Universal Robots**

SAFE & EFFECTIVE EXTRACTION OF WELDING FUMES DIRECTLY AT THE SOURCE.



**CLEAN AIR**

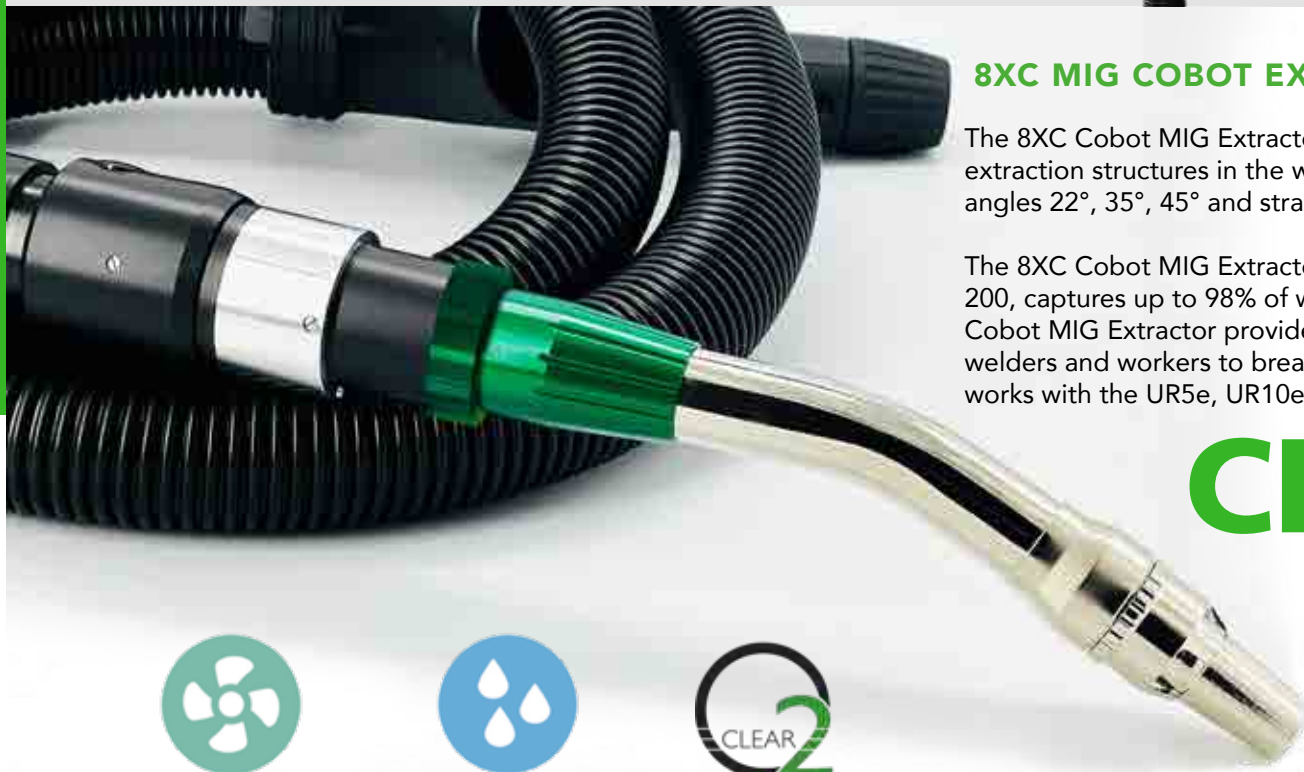

### 8XC MIG COBOT EXTRACTOR

The 8XC Cobot MIG Extractor integrates one of the most efficient fume extraction structures in the welding industry. The torch comes with four different angles 22°, 35°, 45° and straight.

The 8XC Cobot MIG Extractor, combined with the ClearO2 W-series 100 and 200, captures up to 98% of welding fumes directly at the source. The 8XC Cobot MIG Extractor provides one of the safest and most effective solutions for welders and workers to breathe CLEAN AIR and better work environments and works with the UR5e, UR10e & UR16e Universal Robot's.

# CLEAN AIR







# 8XC COBOT MIG EXTRACTOR

## REDUCES WELDING FUMES UP TO 98%

**COBOT  
EXTRACTOR**

### FEATURES

- ✓ ROBUST
- ✓ PATENTED
- ✓ UNIQUE CONTACT TIP FOR MAXIMUM DURABILITY
- ✓ VARIOUS GAS NOZZLES FOR BEST PERFORMANCE
- ✓ DESIGNED FOR ENLARGED ANGULAR MOVEMENT
- ✓ THE SWAN NECK IS SECURED IN TWO PLACES



### HOW DOES IT WORK?

The 8XC MIG Extractor is specially made for Cobot and Semi-Automatic solutions. The 8XC is robust and the unique nozzle design combined with the ClearO2 W-series 100 and 200 provides the best results in taking away the fumes directly at the source. The specially designed nickel-plated contact tips are designed for a longer lifetime. The contact tips are available for all types of wire and sizes. The 8XC cobot works on the UR5e, UR10e and UR16e Universal Robot's.



**UR5e**  
5 kg | 11 lb  
500 mm | 19.7 in

**UR10e**  
10 kg | 22 lb  
850 mm | 33.5 in

**UR16e**  
16 kg | 35.3 lb  
1300 mm | 51.2 in

**UNIQUE NOZZLE DESIGN FOR OPTIMAL PERFORMANCE AND DURABILITY.**

The nozzle design is unique to provide the best results. Openings, wall thickness and grip ribs are thoroughly developed for optimal operation and best performance.

### WIRE FEED CONNECTORS

The 8XC MIG Extractor is as standard fitted with a EURO connector and like other Translas MIG lines available to fit any type of machine.

**EXTRACTION**





# 8XC COBOT MIG EXTRACTOR LINE

**COBOT**  
EXTRACTOR



8XC MIG COBOT

**250**  
**MINI**

**AIR**  
**COOLED**

CO<sub>2</sub> - 280 AMP  
Mixed Gases - 250 AMP  
Duty Cycle - 100%



8XC MIG COBOT

**500**

**WATER**  
**COOLED**

CO<sub>2</sub> - 550 AMP  
Mixed Gases - 500 AMP  
Duty Cycle - 100%

**EXTRACTION**

# 8XC MINI COBOT MIG EXTRACTOR

CO2 - 280 AMP, MIXED GASES - 250 AMP, DUTY CYCLE - 100%



AIR COOLED

CLEAN AIR

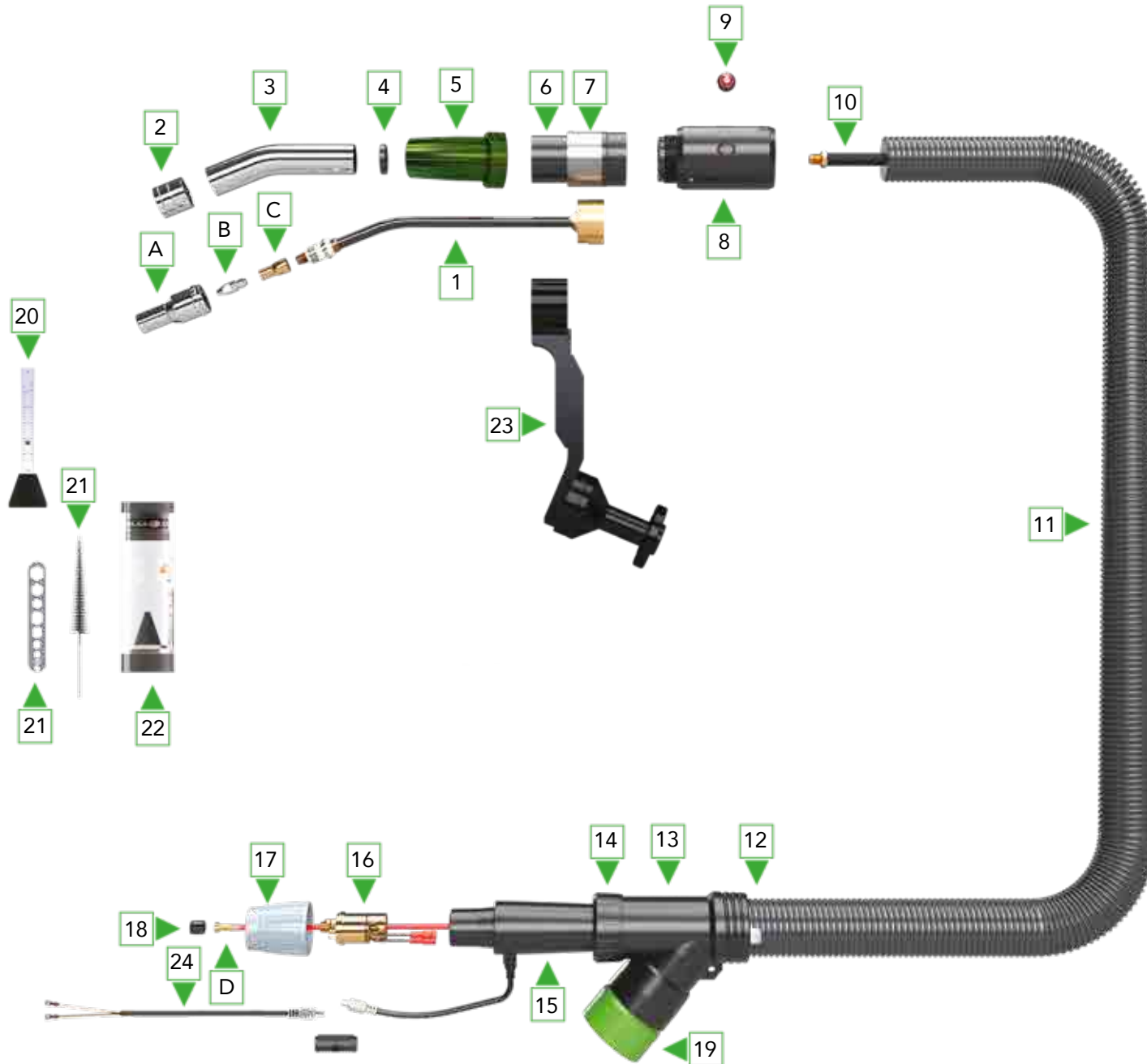

PART NO.	DESCRIPTION	PACK QTY
<b>COMPLETE TORCHES</b>		
Standard with external switch cable (item 24) connected to spring pins		
Standard without torch holder set (item 23)		
8XC6200201080	8XC Cobot Extractor MINI 2mtr with 22° neck	1
8XC6200301080	8XC Cobot Extractor MINI 3mtr with 22° neck	1
8XC6200401080	8XC Cobot Extractor MINI 4mtr with 22° neck	1
8XC6400201080	8XC Cobot Extractor MINI 2mtr with 45° neck	1
8XC6400301080	8XC Cobot Extractor MINI 3mtr with 45° neck	1
8XC6400401080	8XC Cobot Extractor MINI 4mtr with 45° neck	1
8XC6000201080	8XC Cobot Extractor MINI 2mtr with Straight neck	1
8XC6000301080	8XC Cobot Extractor MINI 3mtr with Straight neck	1
8XC6000401080	8XC Cobot Extractor MINI 4mtr with Straight neck	1
<b>Additional options</b>		
8XC*****90	Execution with Push-button switch connected to springpins (item 9)	
8XC*****91	Execution with Push-button switch connected to external connector (item 9 & 24)	

ITEM	PART NO.	DESCRIPTION	PACK QTY
<b>CONSUMABLES</b>			
A	3937000	Nozzle 8XC/8XE Extractor MINI 12mm	5
	3937001	Nozzle 8XC/8XE Extractor MINI 14mm special	5
	3937002	Nozzle 8XC/8XE Extractor MINI 14mm	5
	3937005	Nozzle 8XC/8XE Extractor MINI 17mm special	5
B	399008	Contact tip 8XC/8XE - 0,8	25
	399010	Contact tip 8XC/8XE - 1,0	25
	399012	Contact tip 8XC/8XE - 1,2	25
	3990102	Contact tip 8XC/8XE - 1,0 Alu	25
	3990122	Contact tip 8XC/8XE - 1,2 Alu	25
	3990101	Contact tip 8XC/8XE - 1,0 CuCrZr	25
	3990121	Contact tip 8XC/8XE - 1,2 CuCrZr	25
C	39327110	8XC/8XE Tip adapter MINI	10
D	301525	Plastic coated liner blue (2,0/4,5) 2mtr -for 0,8mm wire	1
	301535	Plastic coated liner blue (2,0/4,5) 3mtr -for 0,8mm wire	1
	301545	Plastic coated liner blue (2,0/4,5) 4mtr -for 0,8mm wire	1
	302525	Plastic coated liner red (2,0/4,5) 2mtr -for 1,0/1,2mm wire	1
	302535	Plastic coated liner red (2,0/4,5) 3mtr -for 1,0/1,2mm wire	1
	302545	Plastic coated liner red (2,0/4,5) 4mtr -for 1,0/1,2mm wire	1
	304829	Graphite liner black (2,0/4,0) 2mtr combiliner- for 1,0/1,2mm wire	1
	304830	Graphite liner black (2,0/4,0) 3mtr combiliner- for 1,0/1,2mm wire	1
	304831	Graphite liner black (2,0/4,0) 4mtr combiliner- for 1,0/1,2mm wire	1



ITEM	PART NO.	DESCRIPTION	PACK QTY
<b>SPARE PARTS</b>			
1	3980122	8XC Swanneck MINI 22°	1
	3980145	8XC Swanneck MINI 45°	1
	3980100	8XC Swanneck MINI straight	1
	3950005	PEEK ring for 8XC/8XE swanneck MINI (not shown)	5
2	3950100	8XC Nozzle holder MINI	1
3	3980522	8XC Metal neck 22°	1
	39502453	8XC Metal neck 45° (partnumber 3980601 is needed)	1
	3980601	8XC Metal neck connector for 45° neck	1
	3980500	8XC Metal neck straight	1
4	3980490	8XC Centre ring for swanneck MINI	1
5	39804411	8XC Adapter metal neck green	1
6	3980400	8XC Torch body	1
7	3980405	8XC Centre bush	1
	3980410	8XC Centre screw M4 (not shown - 3 pieces is needed)	5
8	3980700	8XC Connection set	1
9	3501575	Push-button switch red	2
10	259262XR	Coax cable 8XC MINI 2mtr	1
	259263XR	Coax cable 8XC MINI 3mtr	1
	259264XR	Coax cable 8XC MINI 4mtr	1
11	3402022	Fume cover hose 8XC/8XE 36-44mm 2mtr	1
	3402032	Fume cover hose 8XC/8XE 36-44mm 3mtr	1
	3402042	Fume cover hose 8XC/8XE 36-44mm 4mtr	1
12	398030	Hose connection	1
13	398100	Housing (Y-shape) for fume extraction hose	1
14	398015	Connection ring	1
15	398010	Housing set for central connector	1
16	305298E23	Central connector Euro air-cooled	1
17	8M9420	Adaptor nut	2
18	305316	Liner positioner nut	10
19	398110	Hose adapter	1
20	406050	Gasflow meter	1
21	371208	Tool set (brush and multitool)	1
22	371350	Airflow meter 8XE/8XC Extractor MINI	1
23	3991022	8XC Torchholder set 22°	1
24	Please ask	Push Button connection (also in combination with item 9)	1

# 8XC COBOT MIG EXTRACTOR

CO2 - 550 AMP, MIXED GASES - 500 AMP, DUTY CYCLE - 100%



WATER COOLED

CLEAN AIR

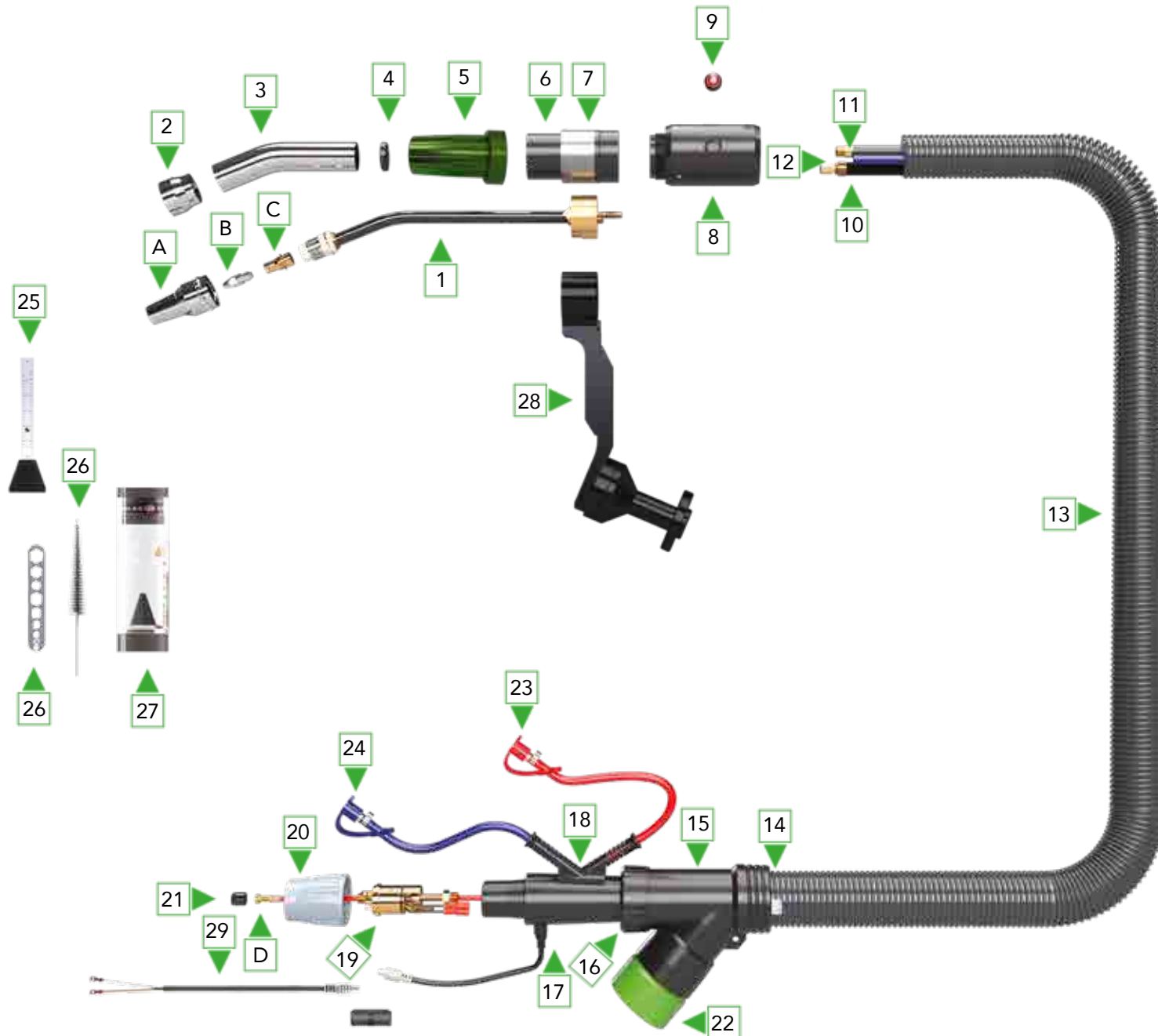

PART NO.	DESCRIPTION	PACK QTY
<b>COMPLETE TORCHES</b>		
	Standard with external switch cable (item 29) connected to spring pins	
	Standard without torch holder set (item 28)	
8XC9260201080	8XC Cobot Extractor water cooled 2mtr with 22° neck	1
8XC9260301080	8XC Cobot Extractor water cooled 3mtr with 22° neck	1
8XC9260401080	8XC Cobot Extractor water cooled 4mtr with 22° neck	1
8XC9460201080	8XC Cobot Extractor water cooled 2mtr with 45° neck	1
8XC9460301080	8XC Cobot Extractor water cooled 3mtr with 45° neck	1
8XC9460401080	8XC Cobot Extractor water cooled 4mtr with 45° neck	1
8XC9060201080	8XC Cobot Extractor water cooled 2mtr with Straight neck	1
8XC9060301080	8XC Cobot Extractor water cooled 3mtr with Straight neck	1
8XC9060401080	8XC Cobot Extractor water cooled 4mtr with Straight neck	1
8XC*****90	Execution with Push-button switch connected to springpins (item 9)	
8XC*****91	Execution with Push-button switch connected to external connector (item 9 & 29)	

ITEM	PART NO.	DESCRIPTION	PACK QTY
<b>CONSUMABLES</b>			
A	3937041	Nozzle 8XC/8XE Extractor 14mm special	5
	3937045	Nozzle 8XC/8XE Extractor 17mm special	5
B	399008	Contact tip 8XC/8XE - 0,8	25
	399010	Contact tip 8XC/8XE - 1,0	25
	399012	Contact tip 8XC/8XE - 1,2	25
	399016	Contact tip 8XC/8XE - 1,6	25
	3990102	Contact tip 8XC/8XE - 1,0 Alu	25
	3990122	Contact tip 8XC/8XE - 1,2 Alu	25
	3990101	Contact tip 8XC/8XE - 1,0 CuCrZr	25
	3990121	Contact tip 8XC/8XE - 1,2 CuCrZr	25
	3990161	Contact tip 8XC/8XE - 1,6 CuCrZr	25
C	39327210	8XC/8XE Tip adapter	10
D	301525	Plastic coated liner blue (2,0/4,5) 2mtr -for 0,8mm wire	1
	301535	Plastic coated liner blue (2,0/4,5) 3mtr -for 0,8mm wire	1
	301545	Plastic coated liner blue (2,0/4,5) 4mtr -for 0,8mm wire	1
	302525	Plastic coated liner red (2,0/4,5) 2mtr -for 1,0/1,2mm wire	1
	302535	Plastic coated liner red (2,0/4,5) 3mtr -for 1,0/1,2mm wire	1
	302545	Plastic coated liner red (2,0/4,5) 4mtr -for 1,0/1,2mm wire	1
	303625	Plastic coated liner yellow (2,4/4,5) 2mtr -for 1,6mm wire	1
	303635	Plastic coated liner yellow (2,4/4,5) 3mtr -for 1,6mm wire	1
	303645	Plastic coated liner yellow (2,4/4,5) 4mtr -for 1,6mm wire	1
	304829	Graphite liner black (2,0/4,0) 2mtr combiliner- for 1,0/1,2mm wire	1
	304830	Graphite liner black (2,0/4,0) 3mtr combiliner- for 1,0/1,2mm wire	1
	304831	Graphite liner black (2,0/4,0) 4mtr combiliner- for 1,0/1,2mm wire	1
	3048341	Graphite liner black (2,3/4,7) 2mtr combiliner- for 1,6mm wire	1
	3048351	Graphite liner black (2,3/4,7) 3mtr combiliner- for 1,6mm wire	1
	3048361	Graphite liner black (2,3/4,7) 4mtr combiliner- for 1,6mm wire	1



ITEM	PART NO.	DESCRIPTION	PACK QTY
<b>SPARE PARTS</b>			
1	3980022	8XC Swanneck water cooled 22°	1
	3980045	8XC Swanneck water cooled 45°	1
	3980000	8XC Swanneck water cooled straight	1
	3950205	PEEK ring for 8XC/8XE swanneck air/water (not shown)	5
2	3950200	Nozzle holder for 8XC/8XE Nozzle	1
3	3980522	8XC Metal neck 22°	1
	39502453	8XC Metal neck 45° (partnumber 3980601 is needed)	1
	3980601	8XC Metal neck connector for 45° neck	1
	3980500	8XC Metal neck straight	1
4	3980480	8XC Centre ring for swanneck	1
5	39804411	8XC Adapter metal neck green	1
6	3980400	8XC Torch body	1
7	3980405	8XC Centre bush	1
	3980410	8XC Centre srew M4 (not shown - 3 pieces is needed)	5
8	3980700	8XC Connection set	1
9	3501575	Push-button switch red	2
10	258512X8R	Power/water cable 8XC/8XE 2mtr	1
	258513X8R	Power/water cable 8XC/8XE 3mtr	1
	258514X8R	Power/water cable 8XC/8XE 4mtr	1
11	2585312XR	Outer liner 8XC/8XE 2mtr	1
	2585313XR	Outer liner 8XC/8XE 3mtr	1
	2585314XR	Outer liner 8XC/8XE 4mtr	1
12	258535	Water inlet hose 5x8mm blue per mtr	100
	258566	Water outlet hose 5x8mm red per mtr	100
13	3402022	Fume cover hose 8XC/8XE 36-44mm 2mtr	1
	3402032	Fume cover hose 8XC/8XE 36-44mm 3mtr	1
	3402042	Fume cover hose 8XC/8XE 36-44mm 4mtr	1
14	398030	Hose connection	1
15	398100	Housing (Y-shape) for fume extraction hose	1
16	398015	Connection ring	1
17	398010	Housing set for central connector	1
18	350881	Water hose guide	1
19	305304E23	Central connector Euro watercooled	1
20	8M9420	Adaptor nut	2
21	305316	Liner positioner nut	10
22	398110	Hose adapter	1
23	258701	Waterstop red	10
24	258702	Waterstop blue	10
25	406050	Gasflow meter	1
26	371208	Tool set (brush and multitool)	1
27	371300	Airflow meter 8XE/8XC Extractor	1
28	3991022	8XC Torchholder set 22°	1
29	Please ask	Push Button connection (also in combination with item 9)	1



EXTRACTION





# 8XC COBOT MIG EXTRACTOR

CONSUMABLES TO FIT YOUR SPECIFIC WELDING APPLICATION

**COBOT  
EXTRACTOR**

The specially designed nickel-plated contact tips for the complete 8XC Cobot & 8XE MIG Extractor series are designed for a longer lifetime.

## CONTACT TIPS



### You can choose from:

- Standard copper for everyday welding.
- Available in sizes from .030" (0.8mm) - .095" (2.4mm.)
- Special tips for aluminum welding.

## WIRE FEED CONNECTORS

### EURO CONNECTOR

There are wire feed connectors available to fit any type of machine. Due to the design of the backend housing, you can switch between the connector types with ease.



## MAINTENANCE

### AIRFLOW METER

Always use the Airflow meter to ensure maximum extraction effect.

### GAS METER

The gas meter is used for best weld quality by keeping the right amount of shielding gas around the weld seam.

### CERAMIC SPRAY

Prolong the life of your gun and all spare parts by applying the ceramic spray to the 8XE and 8XC Extractor before work.



## FREE DRIVE BUTTON

## NOZZLE OPTIONS

There are different nozzle variations to suit any kind of joint application and deliver best welding results. The nozzles can be changed in a second.

### 8XC & 8XE REGULAR

#### 14mm-Special

Where space is limited and fit is tight, this nozzle offers better access and more excellent shielding gas coverage to prevent porosity. This 14mm special nozzle is delivered as a standard on every extractor torch.



### 8XC & 8XE REGULAR

#### 17mm-Special

For heavier-thickness, high-current and high-deposition butt and lap joint applications, this nozzle offers more excellent shielding gas coverage to prevent porosity.



## LINERS

Choose the right liner for your wire diameter and type when working with a 8XE & 8XC Extractor Torch:



All liner types are suitable for stainless steel applications. For Aluminium application, there are the following types:

**Blue , Red and Yellow in Teflon and Graphite.**

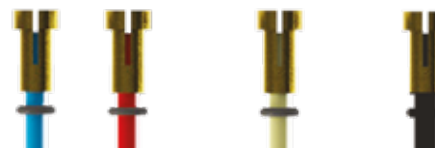

**EXTRACTION**



**TRANSLAS**   
DUTCH WELDING TECHNOLOGY

8TE TIG EXTRACTOR

# EXTRACTION

HARMFUL PARTICULATE ELIMINATED, ONLY CLEAN AIR





# 8TE TIG EXTRACTOR



# CLEAN AIR

## SOURCE EXTRACTION

The 8TE TIG Extractor offers break through integrated at-source fume extraction for the TIG welding process.

### DID YOU KNOW?

Stainless steel and aluminum welding produces the most toxic particulates that are found in the harmful welding fumes because of Hexavalent Chromium and Manganese .

### VARIOUS SWITCH MODULES AVAILABLE.

Positioned at approximately 5 degrees, the switch module eliminates any tension in the fingers and minimizes the risk of cramps due to daily repetitive movements.

### EXTREMELY FLEXIBLE HOSE ON FIRST METER

The 8TE Extractor has an extremely flexible vacuum hose specifically the first one meter from the handle

**Reduces  
Welding Fumes  
up to 95%**

**Standard  
TIG  
Consumables**

CLEAN AIR





# 8TE TIG EXTRACTOR



## THE NEW 8TE-17 AND 8TE-30 TIG EXTRACTORS

Our TIG Extractors protect the welders and other workers in the factory from harmful fumes and metals like Aluminium, Chromium, Iron, Manganese and Nickel which are possibly released during the welding process.

## SAME CONVENIENT HANDLE AS REGULAR 8XT TORCH.

The 8TE TIG Extractor handle has a unique ergonomic shape designed to suit the shape of the welder's hand, fitting perfectly between the thumb and index fingers. The grip is made out of a durable but soft 2K TPE rubber. Both the ergonomic shape and the grip material contribute to the excellent stability of the torch during the welding process.



## CLEARO2 T100 / T200

The ClearO2 T100 / T200 portable extraction units offered by Translas were specially engineered to work with the 8TE Extractor to deliver the best results - up to 95% extraction of welding fumes directly at the source.



## PRODUCT FEATURES

- ✓ SOURCE CAPTURE – ON-TORCH FUME EXTRACTION.
- ✓ EXTRACTS UP TO 95% OF HARMFUL WELDING FUMES AND TOXIC PARTICULATES DIRECTLY AT THE SOURCE BEFORE AIRBORNE.
- ✓ ERGONOMIC GRIP/HANDLE ALL-DAY COMFORT AND STABILITY FOR THE WELDER.
- ✓ EXTRACTION NOZZLE FROM PPS WITH AN ALUMINUM RADIATION PROTECTION SHIELD AND INTERCHANGEABLE PARTS.
- ✓ EXTREMELY FLEXIBLE SUCTION HOSE.
- ✓ OPTIONAL: FLAME RETARDANT PROTECTION HOSE.
- ✓ ROTATING CONNECTION COUPLER.
- ✓ CABLE SUPPORT BEHIND Y-PIECE.
- ✓ EFFECTIVE SUCTION FLOW BETWEEN 18-20M<sup>3</sup>.
- ✓ TIG AIRFLOW METER – CAN BE USED WITH ALL TIG TORCHES.

## PCB PROTECTION PLATE

The PCB module is fixed & completely covered by a protection plate, which keep the PCB safe from HF and dirt. The unique gold-plated spring contacts ensure perfect connection with the welding machine.



EXTRACTION





# 8TE TIG EXTRACTOR LINE



**17** AIR COOLED

DC - 140 AMP  
AC/DC - 100 AMP  
Duty Cycle - 35%



**30** WATER COOLED

DC - 320 AMP  
AC/DC - 230 AMP  
Duty Cycle - 100%



**35** WATER COOLED

DC - 320 AMP  
AC/DC - 230 AMP  
Duty Cycle - 100%

EXTRACTION

## 8TE-17 TIG EXTRACTOR

DC - 140 AMP, AC/DC - 100 AMP, DUTY CYCLE - 35%



AIR COOLED

CLEAN AIR

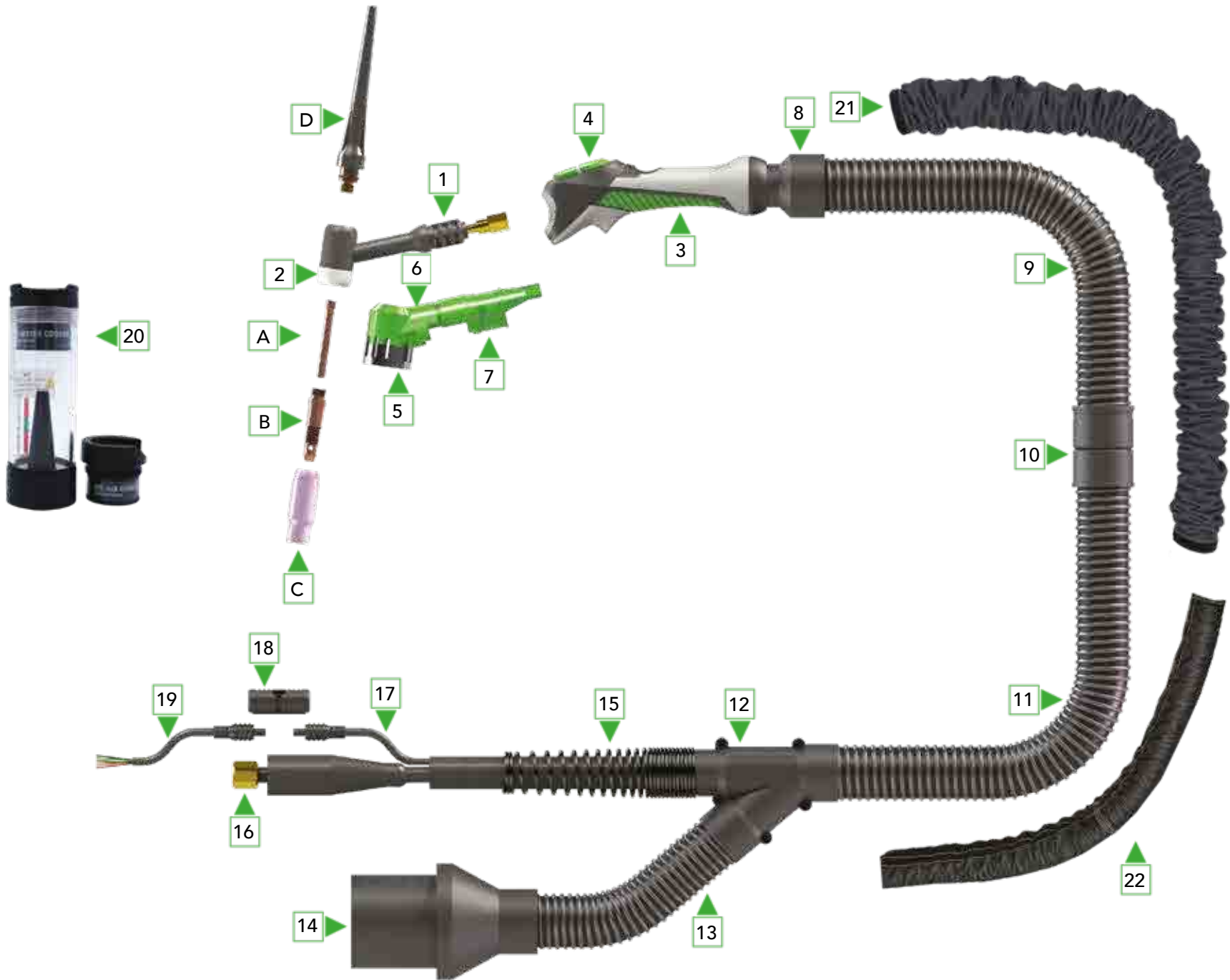



PART NO.	DESCRIPTION	PACK QTY
<b>COMPLETE TORCHES</b>		
8TE20010504350	8TE-17 Tig Extractor 4mtr 10-25mm <sup>2</sup> +1/4'G	1
8TE20010508350	8TE-17 Tig Extractor 8mtr 10-25mm <sup>2</sup> +1/4'G	1
8TE20010504370	8TE-17 Tig Extractor 4mtr 35-50mm <sup>2</sup> +1/4'G	1
8TE20010508370	8TE-17 Tig Extractor 8mtr 35-50mm <sup>2</sup> +1/4'G	1
8TE20010504340	8TE-17 Tig Extractor 4mtr CA Fronius 35-50mm <sup>2</sup>	1
8TE20010508340	8TE-17 Tig Extractor 8mtr CA Fronius 35-50mm <sup>2</sup>	1
8TE20010504000	8TE-17 Tig Extractor 4mtr M12x1	1
8TE20010508000	8TE-17 Tig Extractor 8mtr M12x1	1
8TE20010504210	8TE-17 Tig Extractor 4mtr 1/4'G	1
8TE20010508210	8TE-17 Tig Extractor 8mtr 1/4'G	1
8TE20010504220	8TE-17 Tig Extractor 4mtr 3/8'G	1
8TE20010508220	8TE-17 Tig Extractor 8mtr 3/8'G	1

These 8TE torches come as a standard with a one-button switch module and a trigger cable end without the plug. For other switch options and triggers cable end with plug, we refer to pages 46 and 47.



ITEM	PART NO.	DESCRIPTION	PACK QTY
<b>CONSUMABLES</b>			
A	500664	10N22 Collet 1.0mm	5
	500666	10N23 Collet 1.6mm	5
	500668	70062 Collet 2.0mm	5
	500670	10N24 Collet 2,4mm	5
	500674	10N25 Collet 3.2mm	5
	500676	54N20 Collet 4.0mm	5
B	500764	10N30 Collet body 1.0mm	5
	500766	10N31 Collet body 1.6mm	5
	500768	70064 Collet body 2.0mm	5
	500770	10N32 Collet body 2,4mm	5
	500774	10N28 Collet body 3.2mm	5
	500776	406488 Collet body 4.0mm	5
C	500520	10N50 Ceramic cup 6.4mm	10
	500522	10N49 Ceramic cup 7.9mm	10
	500524	10N48 Ceramic cup 9,5mm	10
	500526	10N47 Ceramic cup 11.1mm	10
	500528	10N46 Ceramic cup 12.7mm	10
	500530	10N45 Ceramic cup 16.0mm	10
	500532	10N44 Ceramic cup 19.0mm	10
D	500346	57Y02 Back cap long	5
	500347	300M Back cap medium	5

ITEM	PART NO.	DESCRIPTION	PACK QTY
<b>SPARE PARTS</b>			
1	520200	Torch body air cooled	1
2	500402	18CG Heat shield	5
3	8X9987	Handle green complete with 1-button switch	1
	580150	Inside handle stop (Not shown)	1
	580160	Inside hose stop (Not shown)	2
4	8X9518	Switch module green 1-button complete	1
		For other switch options we refer to page 47	
5	581010	Heat shield aluminium	1
6	5803502	Suction head	1
7	5801002	Torchbody adaptor	1
8	581050	Ball-and-socket joint	1
9	580400	Suction hose front 1mtr black	1
10	5810602	Connection part for 25mm hose (When torch is 4mtr)	1
	5810622	Connection part for 30mm hose (When torch is 8mtr)	1
11	340102	Suction hose 25mm black p/mtr (When torch is 4mtr)	1 <sub>mtr</sub>
	340505	Suction hose 30mm black p/mtr (When torch is 8mtr)	1 <sub>mtr</sub>
12	5802002	Y-Piece set	1
	5802302	Inside stop to block suction smoke (Not shown)	1
	580250	Adaptor to fit 30mm hose on Y-Piece (When torch is 8mtr)	1
13	340102	Suction hose 25mm black p/mtr	1 <sub>mtr</sub>
14	581068	Adaptor Suction hose 25mm -> 56mm	1
	581069	Adaptor Suction hose 25mm -> 38mm	1
15	580215	Spring 27mm for Y-Piece	1
16		Power/Water cable On request as this is depending on machine connection	1
17	306550	Switch cable 4mtr (QuickConnect)	1
	306552	Switch cable 8mtr (QuickConnect)	1
18	306545	Locking clip (QuickConnect)	1
19	306559	Switch cable end without plug (QuickConnect)	1
20	585000	Airflow meter Extractor	1
21	442352	Hose Cover (Optional)	1
22	582004	Leather Cover for 4mtr torch (optional)	1
	260027	Leather Cover for 8mtr torch (optional)	1

For other Switch cable ends with plug, we refer to Page 46

## 8TE-30 TIG EXTRACTOR

DC - 320 AMP, AC/DC - 330 AMP, DUTY CYCLE - 100%



WATER COOLED

CLEAN AIR

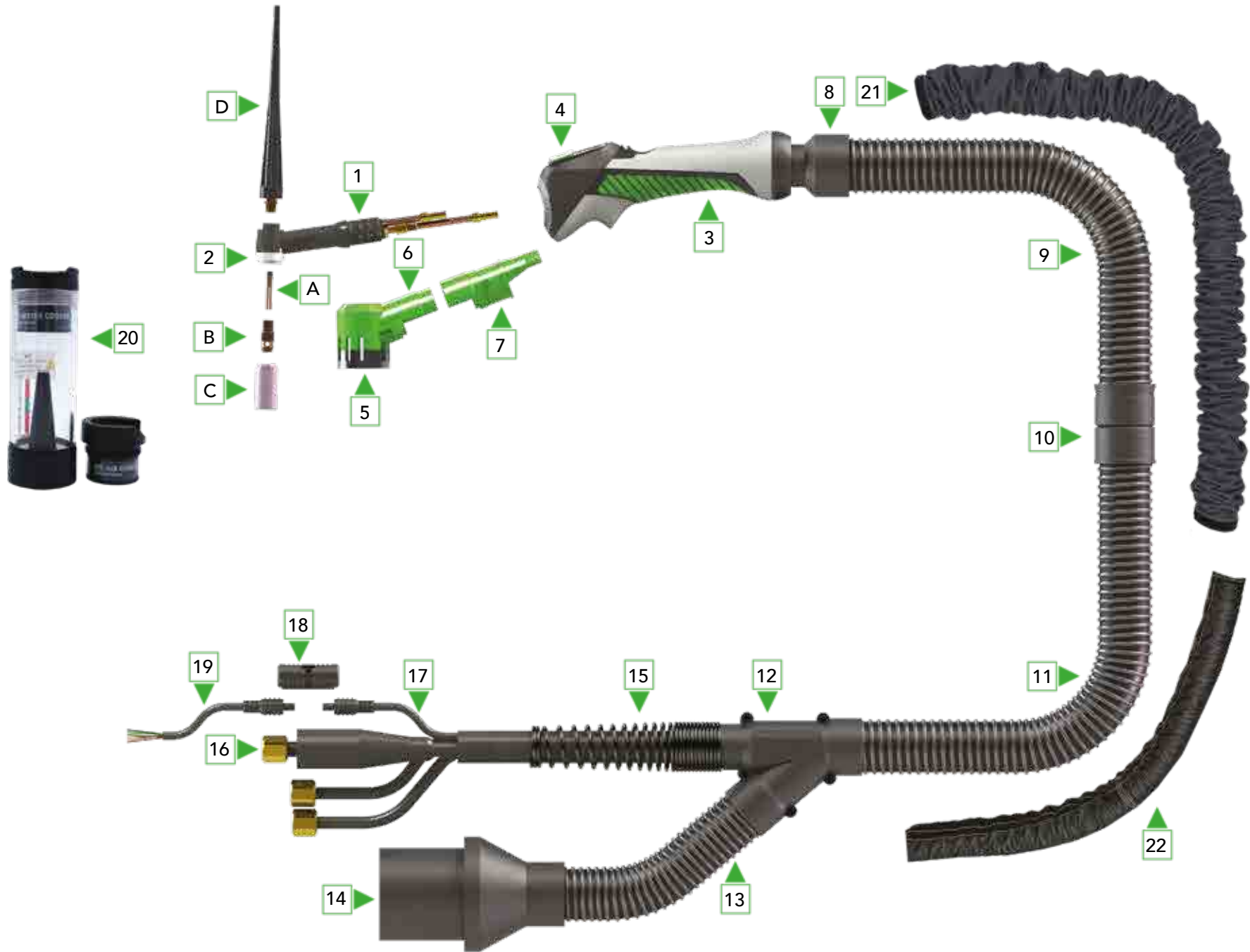

PART NO.	DESCRIPTION	PACK QTY
<b>COMPLETE TORCHES</b>		
8TE60014704650	8TE-30 Tig Extractor 4mtr 35-50mm <sup>2</sup> +tules+1/4'G	1
8TE60014708650	8TE-30 Tig Extractor 8mtr 35-50mm <sup>2</sup> +tules+1/4'G	1
8TE60014704990	8TE-30 Tig Extractor 4mtr CA Fronius 35-50mm <sup>2</sup> +tules	1
8TE60014708990	8TE-30 Tig Extractor 8mtr CA Fronius 35-50mm <sup>2</sup> +tules	1
8TE60014704600	8TE-30 Tig Extractor 4mtr M12x1+3/8'G+1/4'G	1
8TE60014708600	8TE-30 Tig Extractor 8mtr M12x1+3/8'G+1/4'G	1
8TE60014704800	8TE-30 Tig Extractor 4mtr 3/8'G+3/8'G+1/4'G	1
8TE60014708800	8TE-30 Tig Extractor 8mtr 3/8'G+3/8'G+1/4'G	1

These 8TE torches come as a standard with a one-button switch module and a trigger cable end without the plug. For other switch options and triggers cable end with plug, we refer to pages 46 and 47.

ITEM	PART NO.	DESCRIPTION	PACK QTY
<b>CONSUMABLES</b>			
A	500650	13N20 Collet 0,5mm	5
	500652	13N21 Collet 1,0mm	5
	500654	13N22 Collet 1,6mm	5
	500656	70066 Collet 2,0mm	5
	500658	13N23 Collet 2,4mm	5
	500660	13N24 Collet 3,2mm	5
B	500750	13N25 Collet body 0,5mm	5
	500752	13N26 Collet body 1,0mm	5
	500754	13N27 Collet body 1,6mm	5
	500756	70067 Collet body 2,0mm	5
	500758	13N28 Collet body 2,4mm	5
	500760	13N29 Collet body 3,2mm	5
C	500500	13N08 Ceramic cup 6,4mm Gr. 4	10
	500502	13N09 Ceramic cup 7,9mm Gr. 5	10
	500504	13N10 Ceramic cup 9,5mm Gr. 6	10
	500506	13N11 Ceramic cup 11,1mm Gr. 7	10
	500508	13N12 Ceramic cup 12,7mm Gr. 8	10
	500510	13N13 Ceramic cup 15,9mm Gr. 10	10
D	500344	41V35 Back cap medium	5
	500340	41V24 Back cap long (standard)	5



ITEM	PART NO.	DESCRIPTION	PACK QTY
<b>SPARE PARTS</b>			
1	520700	Torch body water cooled	1
2	500400	598882 Heat shield	5
3	8X9987	Handle green complete with 1-button switch	1
	580150	Inside handle stop (Not shown)	1
	580160	Inside hose stop (Not shown)	2
4	8X9518	Switch module green 1-button complete	1
		For other switch options we refer to page 47	
5	581000	Heat shield aluminium	1
6	5803002	Suction head	1
7	5801002	Torchbody adaptor	1
8	581050	Ball-and-socket joint	1
9	580400	Suction hose front 1mtr black	1
10	5810602	Connection part for 25mm hose (When torch is 4mtr)	1
	5810622	Connection part for 30mm hose (When torch is 8mtr)	1
11	340102	Suction hose 25mm black p/mtr (When torch is 4mtr)	1mtr
	340505	Suction hose 30mm black p/mtr (When torch is 8mtr)	1mtr
12	5802002	Y-Piece set	1
	5802202	Inside stop to block suction smoke (Not shown)	1
	580250	Adaptor to fit 30mm hose on Y-Piece (When torch is 8mtr)	1
13	340102	Suction hose 25mm black p/mtr	1mtr
14	581068	Adaptor Suction hose 25mm -> 56mm	1
	581069	Adaptor Suction hose 25mm -> 38mm	1
15	580215	Spring 27mm for Y-Piece	1
16		Power/Water cable On request as this is depending on machine connection	1
17	306550	Switch cable 4mtr (QuickConnect)	1
	306552	Switch cable 8mtr (QuickConnect)	1
18	306545	Locking clip (QuickConnect)	1
19	306559	Switch cable end without plug (QuickConnect)	1
20	585000	Airflow meter Extractor	1
21	442352	Hose Cover (Optional)	1
22	582004	Leather Cover for 4mtr torch (optional)	1
	260027	Leather Cover for 8mtr torch (optional)	1

For other Switch cable ends with plug, we refer to Page 46

## 8TE-35 TIG EXTRACTOR

DC - 320 AMP, AC/DC - 330 AMP, DUTY CYCLE - 100%



WATER COOLED

CLEAN AIR

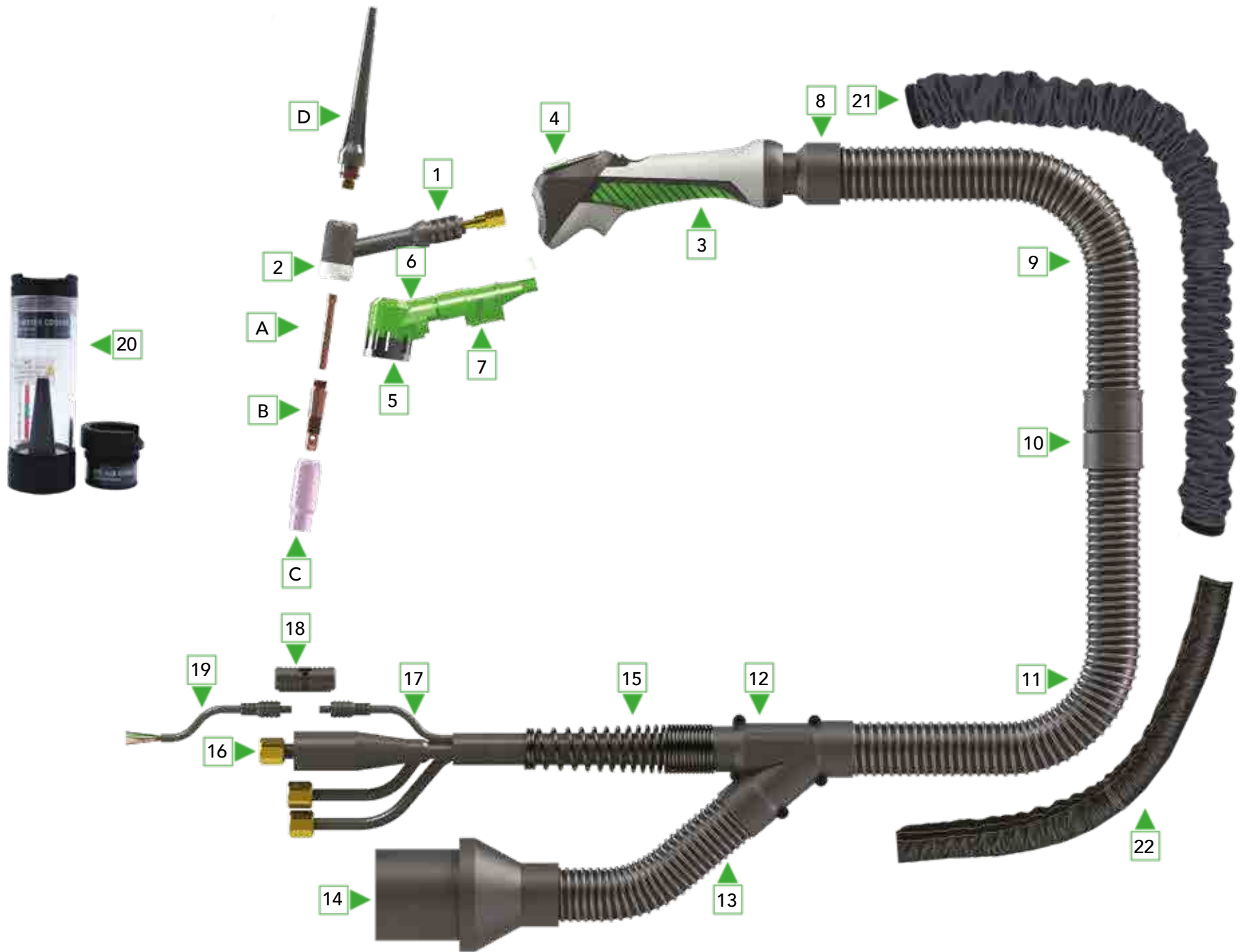

PART NO.	DESCRIPTION	PACK QTY
<b>COMPLETE TORCHES</b>		
8TE65014704650	8TE-35 Tig Extractor 4mtr 35-50mm <sup>2</sup> +tules+1/4'G	1
8TE65014708650	8TE-35 Tig Extractor 8mtr 35-50mm <sup>2</sup> +tules+1/4'G	1
8TE65014704990	8TE-35 Tig Extractor 4mtr CA Fronius 35-50mm <sup>2</sup> +tules	1
8TE65014708990	8TE-35 Tig Extractor 8mtr CA Fronius 35-50mm <sup>2</sup> +tules	1
8TE65014704600	8TE-35 Tig Extractor 4mtr M12x1+3/8'G+1/4'G	1
8TE65014708600	8TE-35 Tig Extractor 8mtr M12x1+3/8'G+1/4'G	1
8TE65014704800	8TE-35 Tig Extractor 4mtr 3/8'G+3/8'G+1/4'G	1
8TE65014708800	8TE-35 Tig Extractor 8mtr 3/8'G+3/8'G+1/4'G	1

These 8TE torches come as a standard with a one-button switch module and a trigger cable end without the plug. For other switch options and triggers cable end with plug, we refer to pages 46 and 47.

ITEM	PART NO.	DESCRIPTION	PACK QTY
<b>CONSUMABLES</b>			
A	500664	10N22 Collet 1.0mm	5
	500666	10N23 Collet 1.6mm	5
	500668	70062 Collet 2.0mm	5
	500670	10N24 Collet 2,4mm	5
	500674	10N25 Collet 3.2mm	5
	500676	54N20 Collet 4.0mm	5
B	500764	10N30 Collet body 1.0mm	5
	500766	10N31 Collet body 1.6mm	5
	500768	70064 Collet body 2.0mm	5
	500770	10N32 Collet body 2,4mm	5
	500774	10N28 Collet body 3.2mm	5
	500776	406488 Collet body 4.0mm	5
C	500520	10N50 Ceramic cup 6.4mm	10
	500522	10N49 Ceramic cup 7.9mm	10
	500524	10N48 Ceramic cup 9,5mm	10
	500526	10N47 Ceramic cup 11.1mm	10
	500528	10N46 Ceramic cup 12.7mm	10
	500530	10N45 Ceramic cup 16.0mm	10
	500532	10N44 Ceramic cup 19.0mm	10
D	500346	57Y02 Back cap long	5
	500347	300M Back cap medium	5



ITEM	PART NO.	DESCRIPTION	PACK QTY
<b>SPARE PARTS</b>			
1	520701	Torch body water cooled	1
2	500402	18CG Heat shield	5
3	8X9987	Handle green complete with 1-button switch	1
	580150	Inside handle stop (Not shown)	1
	580160	Inside hose stop (Not shown)	2
4	8X9518	Switch module green 1-button complete	1
		For other switch options we refer to page 47	
5	581000	Heat shield aluminium	1
6	5804102	Suction head	1
7	5801002	Torchbody adaptor	1
8	581050	Ball-and-socket joint	1
9	580400	Suction hose front 1mtr black	1
10	5810602	Connection part for 25mm hose (When torch is 4mtr)	1
	5810622	Connection part for 30mm hose (When torch is 8mtr)	1
11	340102	Suction hose 25mm black p/mtr (When torch is 4mtr)	1mtr
	340505	Suction hose 30mm black p/mtr (When torch is 8mtr)	1mtr
12	5802002	Y-Piece set	1
	5802202	Inside stop to block suction smoke (Not shown)	1
	580250	Adaptor to fit 30mm hose on Y-Piece (When torch is 8mtr)	1
13	340102	Suction hose 25mm black p/mtr	1mtr
14	581068	Adaptor Suction hose 25mm -> 56mm	1
	581069	Adaptor Suction hose 25mm -> 38mm	1
15	580215	Spring 27mm for Y-Piece	1
16		Power/Water cable On request as this is depending on machine connection	1
17	306550	Switch cable 4mtr (QuickConnect)	1
	306552	Switch cable 8mtr (QuickConnect)	1
18	306545	Locking clip (QuickConnect)	1
19	306559	Switch cable end without plug (QuickConnect)	1
20	585000	Airflow meter Extractor	1
21	442352	Hose Cover (Optional)	1
22	582004	Leather Cover for 4mtr torch (optional)	1
	260027	Leather Cover for 8mtr torch (optional)	1

For other Switch cable ends with plug, we refer to Page 46



# 8TE TIG EXTRACTOR



CLEAN AIR

SWITCH CABLE ENDS



## CONFIGURATION SHEET

With this configuration sheet, you can easily select the plug applicable for the various welding machines. You can also select the switch types and water- or gas-cooled applications.

ITEM	PART NO.	MACHINE BRAND	PLUG TYPE	GAS COOLED	WATER COOLED	ONE BUTTON	TWO BUTTON	THREE BUTTON	FOUR BUTTON	ONE BUTTON POT
1	507541	Cebora	10-pins Cebora	<input checked="" type="checkbox"/>	<input checked="" type="checkbox"/>	<input checked="" type="checkbox"/>		<input checked="" type="checkbox"/>		<input checked="" type="checkbox"/>
	507549	Cebora	10-pins Cebora	<input checked="" type="checkbox"/>	<input checked="" type="checkbox"/>	<input checked="" type="checkbox"/>				<input checked="" type="checkbox"/>
2	507450	Esab	2-pins Amphenol	<input checked="" type="checkbox"/>	<input checked="" type="checkbox"/>	<input checked="" type="checkbox"/>				
	5004623	EWM, Lincoln, Saf Oerlikon	5-pins Tüchel	<input checked="" type="checkbox"/>	<input checked="" type="checkbox"/>	<input checked="" type="checkbox"/>	<input checked="" type="checkbox"/>			
4	507714	EWM	8-pins UTG	<input checked="" type="checkbox"/>	<input checked="" type="checkbox"/>	<input checked="" type="checkbox"/>	<input checked="" type="checkbox"/>	<input checked="" type="checkbox"/>	<input checked="" type="checkbox"/>	
	507552	Jäckle	5-pins Tüchel	<input checked="" type="checkbox"/>	<input checked="" type="checkbox"/>	<input checked="" type="checkbox"/>	<input checked="" type="checkbox"/>			
3	507550	Jäckle	5-pins Tüchel	<input checked="" type="checkbox"/>	<input checked="" type="checkbox"/>	<input checked="" type="checkbox"/>		<input checked="" type="checkbox"/>	<input checked="" type="checkbox"/>	
	507561	Jäckle	7-pins Tüchel	<input checked="" type="checkbox"/>	<input checked="" type="checkbox"/>					<input checked="" type="checkbox"/>
6	50048227	Fronius	9-pins Fronius	<input checked="" type="checkbox"/>	<input checked="" type="checkbox"/>	<input checked="" type="checkbox"/>	<input checked="" type="checkbox"/>	<input checked="" type="checkbox"/>		
	50048247	Fronius	9-pins Fronius	<input checked="" type="checkbox"/>	<input checked="" type="checkbox"/>				<input checked="" type="checkbox"/>	
7	507435	Kemppi	4-pins Amphenol	<input checked="" type="checkbox"/>	<input checked="" type="checkbox"/>	<input checked="" type="checkbox"/>				
	5075371	Kemppi	7-pins Amphenol MLS	<input checked="" type="checkbox"/>		<input checked="" type="checkbox"/>		<input checked="" type="checkbox"/>		
8	5075372	Kemppi	7-pins Amphenol MLS		<input checked="" type="checkbox"/>	<input checked="" type="checkbox"/>		<input checked="" type="checkbox"/>		
	5075373	Kemppi	7-pins Amphenol MLS	<input checked="" type="checkbox"/>						<input checked="" type="checkbox"/>
	5075374	Kemppi	7-pins Amphenol MLS		<input checked="" type="checkbox"/>					<input checked="" type="checkbox"/>
	507611	Migatronc	7-pins Amphenol	<input checked="" type="checkbox"/>		<input checked="" type="checkbox"/>				<input checked="" type="checkbox"/>
9	507621	Migatronc	7-pins Amphenol		<input checked="" type="checkbox"/>	<input checked="" type="checkbox"/>				<input checked="" type="checkbox"/>
	507612	Rehm	7-pins Amphenol	<input checked="" type="checkbox"/>		<input checked="" type="checkbox"/>	<input checked="" type="checkbox"/>			
9	507613	Rehm	7-pins Amphenol		<input checked="" type="checkbox"/>	<input checked="" type="checkbox"/>	<input checked="" type="checkbox"/>			
	507615	Rehm	7-pins Amphenol	<input checked="" type="checkbox"/>	<input checked="" type="checkbox"/>					<input checked="" type="checkbox"/>



# 8TE TIG EXTRACTOR



## SWITCH MODULE OPTIONS

ITEM	PART NO.	DESCRIPTION	PACK QTY
1	8X9518	8TE Switch module 1-button complete	1
2	8X9528	8TE Switch module 2-button complete	1
3	8X9538	8TE Switch module 3-button complete	1
4	8X9558	8TE Switch module 4-button rocker complete	1
5	8X9578	8TE Switch module 1-button 10 kOhm complete	1
6	8X9560	8TE Switch module 1-button lamelle complete	1

## TIG CONSUMABLES



All international wear parts are stock products and fully interchangeable.

## END FITTINGS

We supply almost every common end fitting for TIG power cables.



## CERAMIC CUPS

Complete range of ceramics is available.



EXTRACTION





**TRANSLAS**   
DUTCH WELDING TECHNOLOGY

CLEARO2 



**HI-VAC UNITS**

# EXTRACTION

**NO FUMES, ONLY CLEAN AIR**





# HI-VAC UNITS INTEGRATED FUME EXTRACTION



**CLEARO2  
UNITS**



## ENGINEERED FOR THE TRANSLAS 8XE MIG, 8XC COBOT & 8TE TIG, EXTRACTOR TORCHES

### Powerful, Flexible & Mobile.

The ClearO2 portable extraction units offered by Translas were specially engineered to work with the 8XE MIG, 8XC Cobot, & 8TE TIG Extractors to deliver the best results - up to 98% extraction of welding fumes directly at the source. The ClearO2 portable extraction units and solutions are ready to use systems, designed for maximum convenience for the welder during work.



**CLEAN AIR**



### AUTOMATIC FILTER CLEANING

The ClearO2 W-series have an automatic cleaning function by reverse compressed air pulse. The moment the under pressure in the filter is too high, the units start to clean the filters automatically. A manual cleaning function can be done by pressing a single button. With a large filter area the ClearO2 Hi-vac units are the most efficient units of their size.



### POWERFUL FILTRATION

With the combination of a 8XE MIG, 8XC Cobot, 8TE TIG Extractor and a ClearO2 unit, the captured fumes are filtered with an efficiency > IFA 99.8%. The powerful solution is suitable for high production welding environments.



### LARGE FILTER AREA

This is one of the most efficient units of it's size with a filter area of 5m<sup>2</sup>.

**EXTRACTION**



# HI-VAC UNITS INTEGRATED FUME EXTRACTION



**CLEAR2  
UNITS**



## EFFICIENT MOTOR SYSTEM

The electric motor of the units is designed to work continuously. Due to the automatic cleaning function and the simplified motor system, the units' maintenance is minimal, making them long-lasting and time saving.

The automatic start/stop function was engineered to preserve energy and synchronize the units with the Translas Extractor guns. The moment the gun is out of the gun holder, the machine automatically starts working.

There are two start/stop options: the clamp, which works on induction, and the gun holder. For both options, after stopping welding or putting the gun back into the holder, the machine stops working after about 20 seconds.

**LIGHT & MOBILE**

**IFA  
99.8%**

**ONLY GENERATES  
65dB**

- ✓ **DESIGNED FOR THE 8XE MIG, 8XC COBOT, & 8TE TIG EXTRACTOR TORCHES**
- ✓ **MOBILE, WITH WHEELS OR CRANE HOOKS**
- ✓ **UNITS FOR 1 - 2 WELDERS**
- ✓ **SUITABLE FOR HIGH-PRODUCTION ENVIRONMENT**
- ✓ **QUIET < 65dB & EFFICIENT**



## AUTO START/STOP OPTIONS

These options are designed to work only with the 8XE MIG, 8XC Cobot, & 8TE TIG Extractors torches by using the clamp auto start/stop.

**EXTRACTION**



CLEAR



CLEAR

Powered by  
FUM  
ATOR  
Absaugtechnik



# MIG CLEARO2 UNITS INTEGRATED FUME EXTRACTION



**CLEARO2  
UNITS**

MIG HI-VAC UNITS



**W  
100** CLEARO2  
UNIT

MIG HI-VAC UNITS



**W  
200** CLEARO2  
UNIT

**EXTRACTION**



# MIG CLEARO2 W100/150 INTEGRATED FUME EXTRACTION

FOR ONE WELDER



**CLEARO2  
UNITS**

**CLEAN AIR**



<b>Dimensions</b>	(L x B x H) 700 x 440 x 585 / 630mm (without / with wheels)
<b>Implementation</b>	Mobile on 4-wheels. Two rotating with locks
<b>Power Supply</b>	(W100) = 220 - 240 V / 50 - 60 Hz (W150) = 380 - 480 V / 50 - 60 Hz
<b>Motor power</b>	Max 1.5 KW
<b>Suction Flow</b>	Max. 180 m <sup>3</sup> /h (free blowing)
<b>Suction Flow Effective</b>	Max. 65m <sup>3</sup> /h
<b>Working Pressure</b>	Max. 36000Pa (el. Controlled)
<b>Filter Surface</b>	5m <sup>2</sup> Active filter surface, Filter efficiency: IFA >99.8%
<b>Working Temperature</b>	0 to +50°C
<b>Max. DC</b>	DC: 100%
<b>Inlet</b>	51 mm
<b>Weight</b>	Ca. 45 kg
<b>Noise Level</b>	Max. dB(A) <65Db(A) (at 100% suction flow)
<b>Filter method</b>	Disposable filter
<b>Certifications</b>	CE, W3, and CSA

PART NO.	DESCRIPTION	PACK QTY
<b>CLEARO2 W100/150</b>		
374610000000	Welding fume unit ClearO2 W100 220 - 240 V 50 - 60 Hz 1.5 KW	1
374615000000	Welding fume unit ClearO2 W150 380 - 420 V 50 - 60 Hz 1.5 KW	1



# MIG CLEARO2 W200

## INTEGRATED FUME EXTRACTION

FOR TWO WELDER



**CLEARO2  
UNITS**



<b>Dimensions</b>	(L x B x H) 700 x 530 x 560 / 630mm (without / with wheels)
<b>Implementation</b>	Mobile on 4-wheels. Two rotating with locks
<b>Power Supply</b>	400 - 480 V / 50 - 60 Hz
<b>Motor power</b>	Max 3.0 KW
<b>Suction Flow</b>	Max. 250 m³/h (free blowing)
<b>Suction Flow Effective</b>	Max. 65m³/h
<b>Working Pressure</b>	Max. 45000Pa (el. Controlled)
<b>Filter Surface</b>	5m² Active filter surface, Filter efficiency: IFA >99.8%
<b>Working Temperature</b>	0 to +50°C
<b>Max. DC</b>	DC: 100%
<b>Inlet</b>	51 mm
<b>Weight</b>	Ca. 58 kg
<b>Noise Level</b>	Max. dB(A) <65Db(A) (at 100% suction flow)
<b>Filter method</b>	Disposable filter
<b>Certifications</b>	CE, W3, and CSA

**EXTRACTION**

PART NO.	DESCRIPTION	PACK QTY
<b>CLEARO2 W200</b>		
3746200000000	Welding fume unit ClearO2 W200 380 - 420 V 50 - 60 Hz 3 KW	1







# TIG CLEARO2 UNITS INTEGRATED FUME EXTRACTION



**CLEARO2  
UNITS**



TIG HI-VAC UNITS

**T**  
**100** CLEARO2  
UNIT



TIG HI-VAC UNITS

**T**  
**200** CLEARO2  
UNIT

**EXTRACTION**



# TIG CLEARO2 T100

## INTEGRATED FUME EXTRACTION

FOR ONE WELDER



**CLEARO2  
UNITS**

**CLEAN AIR**



<b>Dimensions</b>	(L x W x H) 620 x 380 x 465mm
<b>Power Supply</b>	230V/50Hz
<b>Motor Power</b>	1.2 KW
<b>Suction Flow</b>	Max. 125m <sup>3</sup> /h
<b>Suction Flow Effective</b>	Max. 38 CFM (Translas Extractors)
<b>Working Pressure</b>	Max. 30000Pa
<b>Filter Surface</b>	2,5m <sup>2</sup> ( !! Aktive Filteroberfläche !! )
<b>Filter Efficiency</b>	IFA > 99,8%
<b>Inlet</b>	51mm (optional 44mm)
<b>Weight</b>	Ca. 30 kg
<b>Noise Level</b>	Max. dBa (A) < 65dBa (at 100% Suctionflow)
<b>Filter Method</b>	Disposable filter
<b>Certifications</b>	CSA, CE

W3 is under construction.

Option: Start/Stop cable

PART NO.	DESCRIPTION	PACK QTY
<b>CLEARO2 T100</b>		
3756100030000	ClearO2 T100 230V 50Hz 1.2kW	1



# TIG CLEARO2 T200

## INTEGRATED FUME EXTRACTION

FOR TWO WELDERS



**CLEARO2  
UNITS**



<b>Dimensions</b>	(L x B x H) 700 x 440 x 585 / 630mm (without / with wheels)
<b>Implementation</b>	Mobile on 4-wheels. Two rotating with locks
<b>Power Supply</b>	220 - 240 V / 50 - 60 Hz
<b>Motor power</b>	Max 1.5 KW
<b>Suction Flow</b>	Max. 180 m <sup>3</sup> /h (free blowing)
<b>Suction Flow Effective</b>	Max. 65m <sup>3</sup> /h
<b>Working Pressure</b>	Max. 36000Pa (el. Controlled)
<b>Filter Surface</b>	5m <sup>2</sup> Active filter surface, Filter efficiency: IFA >99.8%
<b>Working Temperature</b>	0 to +50°C
<b>Max. DC</b>	DC: 100%
<b>Inlet</b>	51 mm
<b>Weight</b>	Ca. 45 kg
<b>Noise Level</b>	Max. dB(A) <65Db(A) (at 100% suction flow)
<b>Filter method</b>	Disposable filter
<b>Certifications</b>	CE, W3, and CSA

**EXTRACTION**

PART NO.	DESCRIPTION	PACK QTY
<b>CLEARO2 T200</b>		
375620000000	ClearO2 T200 220-240V 50-60Hz 1.5kW	1



# SPARE PARTS FOR HI-VAC UNITS INTEGRATED FUME EXTRACTION



**CLEARO2  
UNITS**

**CLEAN AIR**



PART NUMBER	DESCRIPTION	PACK QTY
374012	Torch holder ø40mm for automatic start/stop 5mtr ClearO2	1
374013	Torch holder ø40mm for automatic start/stop 10mtr ClearO2	1
374014	Torch holder ø50mm for automatic start/stop 5mtr ClearO2	1
374015	Torch holder ø50mm for automatic start/stop 10mtr ClearO2	1

PART NUMBER	DESCRIPTION	PACK QTY
374010	Sensing cable auto start / stop 4mtr W-serie	1

PART NUMBER	DESCRIPTION	PACK QTY
3740103	Extension cable auto start / stop incl. 5-p plug W-serie 3mtr	1
3740105	Extension cable auto start / stop incl. 5-p plug W-serie 5mtr	1
3740110	Extension cable auto start / stop incl. 5-p plug W-serie 10mtr	1

PART NUMBER	DESCRIPTION	PACK QTY
37422505	ClearO2 suction hose black ø51mm 5mtr	1
37422510	ClearO2 suction hose black ø51mm 10mtr	1

PART NUMBER	DESCRIPTION	PACK QTY
374099	Ball valve to reduce the suction flow	1

PART NUMBER	DESCRIPTION	PACK QTY
374106	Pressure reducing value 5 - 15 bar 1/4-NP7.2	10



# SPARE PARTS FOR HI-VAC UNITS

## INTEGRATED FUME EXTRACTION



**CLEARO2  
UNITS**



PART NUMBER	DESCRIPTION	PACK QTY
374020	Filter - 64 Sq Ft (5m2)	1



PART NUMBER	DESCRIPTION	PACK QTY
374025	Filtermat W-serie ClearO2 (set/5pc)	1



PART NUMBER	DESCRIPTION	PACK QTY
374126	Coupler for suction hose black ø51mm 5mtr	1



PART NUMBER	DESCRIPTION	PACK QTY
374130	Coupler to extend the suction hose ø51mm	1



PART NUMBER	DESCRIPTION	PACK QTY
398110	Coupler for suction hose ø51mm side 8XE	1



PART NUMBER	DESCRIPTION	PACK QTY
374149	Y-Branch Adapter for T200	1

**EXTRACTION**







[WWW.KL-SYSTEM.HU](http://WWW.KL-SYSTEM.HU)



+36 53 500 260



2700 Cegléd  
Külső Kátai út 96.  
Hungary



[kl-system@kl-system.hu](mailto:kl-system@kl-system.hu)



[WWW.TRANSLAS.COM](http://WWW.TRANSLAS.COM)